



## Table of Contents

No.	Contents	Page
1.	FEATURES .....	4
2.	MECHANICAL SPECIFICATIONS .....	4
3.	ELECTRICAL SPECIFICATIONS .....	5
4.	TERMINAL FUNCTIONS AND BLOCK DIAGRAM.....	6
5.	TIMING CHARACTERISTICS .....	7
6.	COMMAND LIST .....	8
7.	CHARACTER GENERATOR ROM.....	9
8.	QUALITY SPECIFICATIONS.....	10
9.	RELIABILITY .....	15
10.	HANDLING PRECAUTION .....	16
11.	OUTLINE DIMENSION .....	17

## 1. Features

The features of LCD are showed as follows

- \* Display mode : STN/Y-G/Transflective/Positive
- \* Driver/Controller IC : SPLC780D1-001 (English And Japanese/SPLC063B1)
- \* Display format : 20 X4 Characters
- \* Interface Input Data : 8-Bit
- \* Driving Method : 1/16Duty, 1/5 Bias
- \* Viewing Direction : 6 O'clock
- \* Backlight : LED/Bottom(Yellow-green)
- \* Sample NO. : EC2004A2SBY6B-1.1/2008-10-30

## 2. MECHANICAL SPECIFICATIONS

Item	Specification	Unit
Module Size	98(W) x60(H) x14MAX(T)	mm
Viewing Area	77(W) x 26.5(H)	mm
Activity Display Area	70.4(W) x 20.8(H)	mm
Character Font	5x8 Dots	-
Character Size	2.95(W)x4.75(H)	mm
Character Pitch	3.55(W) x 5.35(H)	mm
Dot Size	0.55(W)x0.55(H)	mm
Dot Pitch	0.6(W)x0.6(H)	mm

## 3. ELECTRICAL SPECIFICATIONS

### 3-1 ABSOLUTE MAXIMUM RATINGS (Ta = 25 °C)

Item	Symbol	Min	Max	Unit
Supply Voltage For Logic	$V_{DD} - V_{SS}$	-0.3	7	V
Supply Voltage For LCD Drive	$V_{OP} = V_{DD} - V_0$	0.3	10	V
Input Voltage	$V_{in}$	-0.3	$V_{DD}+0.3$	V
Operating Temp.	$T_{op}$	-20	+70	°C
Storage Temp.	$T_{st}$	-30	+80	°C

\*. NOTE: The response time will be extremely slow when the operating temperature is around -10°C, and the back ground will become darker at high temperature operating.

### 3-2 ELECTRICAL CHARACTERISTICS

Item	Symbol	Test Condition	Min.	Typ.	Max.	Unit
Logic supply Voltage	$V_{DD} - V_{SS}$	$T_a = 25\text{ }^\circ\text{C}$	4.5	5	5.5	V
LCD Drive	$V_{OP}=V_{DD}-V_0$		4.2	4.5	4.8	V
Input Voltage	"H" Level	$V_{DD}=5V \pm 10\%$	$0.7V_{DD}$	-	$V_{DD}$	V
	"L" Level		-0.3	-	0.55	V
Frame Frequency	$f_{FLM}$	$V_{DD} = 5V$	-	78.1	-	Hz
Current Consumption	$I_{DD}$	$V_{DD} = 5V$	-	1.4	-	mA

### 3-3. BACKLIGHT

#### 3-3-1. Absolute Maximum Ratings

Item	Symbol	Condition	Min.	Typ.	Max.	Unit
Forward Current	IF	$T_a = 25\text{ }^\circ\text{C}$	-	-	180	mA
Reverse Voltage	VR		-	-	4	V
Power Dissipation	PD		-	-	720	mW

#### 3-3-2. Electrical-optical Characteristics

Item	Symbol	Condition	Min.	Typ.	Max.	Unit
Forward Voltage	VF	$T_a = 25\text{ }^\circ\text{C}$ $I_f=180\text{mA}$	3.8	4.0	4.2	V
Average Luminous Intensity	$I_v$		-	130	-	$\text{cd/m}^2$
Peak wavelength	$\lambda$		569	572	575	nm

The brightness is measured without LCD panel

## 4. TERMINAL FUNCTIONS AND BLOCK DIAGRAM

### 4-1 INTERFACE PIN FUNCTION DESCRIPTION

PIN NO.	SYMBOL	FUNCIONS
1	VSS	Ground
2	VDD	Supply voltage for logical circuit
3	V0	Supply voltage for LCD driving
4	RS	A signal for selecting registers. 1: Data Register (for read and write) 0: Instruction Register (for write)
5	R/W	A signal for selecting read or write actions.1: Read, 0: Write.
6	E	A enable signal for reading or writing data.
7-14	DB0~DB7	8 Bit Data Bus
15	LEDA	Backlight(+)
16	LEDK	Backlight(-)

### 4-2 BLOCK DIAGRAM

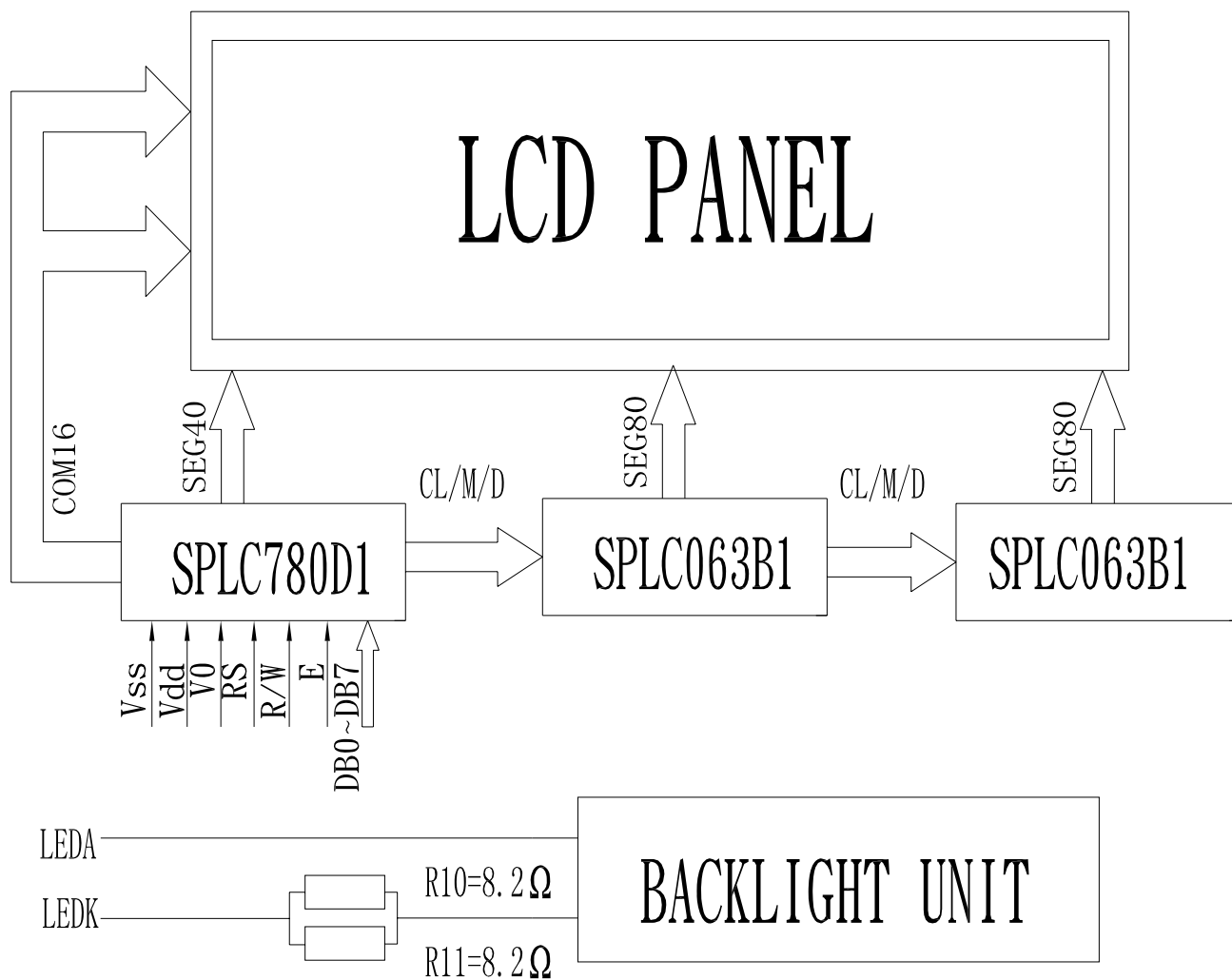

## 5. TIMING CHARACTERISTICS

### 5 - 1 Write mode

Characteristics	Symbol	Limit			Unit	Test Condition
		Min.	Typ.	Max.		
E Cycle Time	$t_c$	400	-	-	ns	Pin E
E Pulse Width	$t_{PW}$	150	-	-	ns	Pin E
E Rise/Fall Time	$t_R, t_F$	-	-	25	ns	Pin E
Address Setup Time	$t_{SP1}$	30	-	-	ns	Pins: RS, R/W, E
Address Hold Time	$t_{HD1}$	10	-	-	ns	Pins: RS, R/W, E
Data Setup Time	$t_{SP2}$	40	-	-	ns	Pins: DB0 - DB7
Data Hold Time	$t_{HD2}$	10	-	-	ns	Pins: DB0 - DB7

### 5-2 Read mode

Characteristics	Symbol	Limit			Unit	Test Condition
		Min.	Typ.	Max.		
E Cycle Time	$t_c$	400	-	-	ns	Pin E
E Pulse Width	$t_W$	150	-	-	ns	Pin E
E Rise/Fall Time	$t_R, t_F$	-	-	25	ns	Pin E
Address Setup Time	$t_{SP1}$	30	-	-	ns	Pins: RS, R/W, E
Address Hold Time	$t_{HD1}$	10	-	-	ns	Pins: RS, R/W, E
Data Output Delay Time	$t_D$	-	-	100	ns	Pins: DB0 - DB7
Data hold time	$t_{HD2}$	5.0	-	-	ns	Pin DB0 - DB7

### 5 - 3 Write mode timing diagram

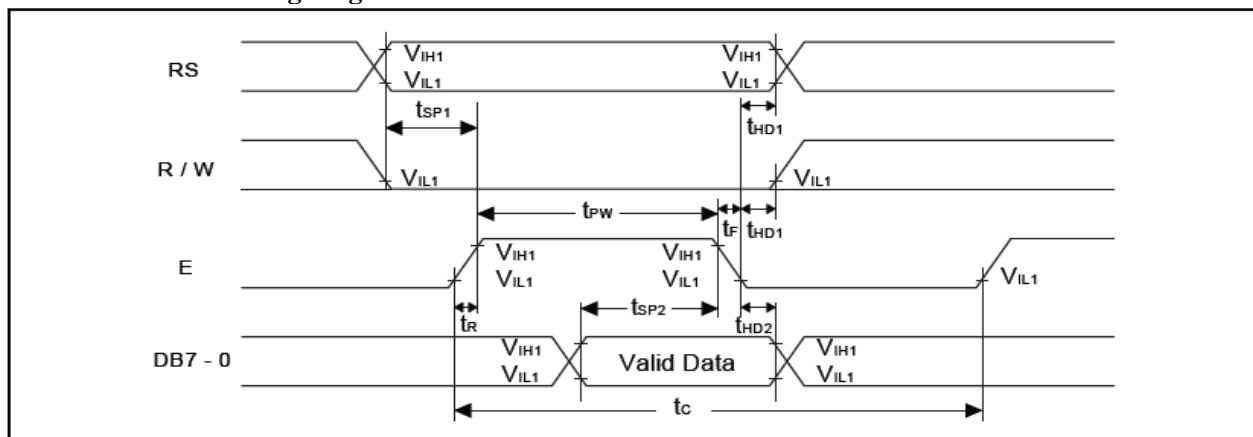

### 5- 4 Read mode timing diagram

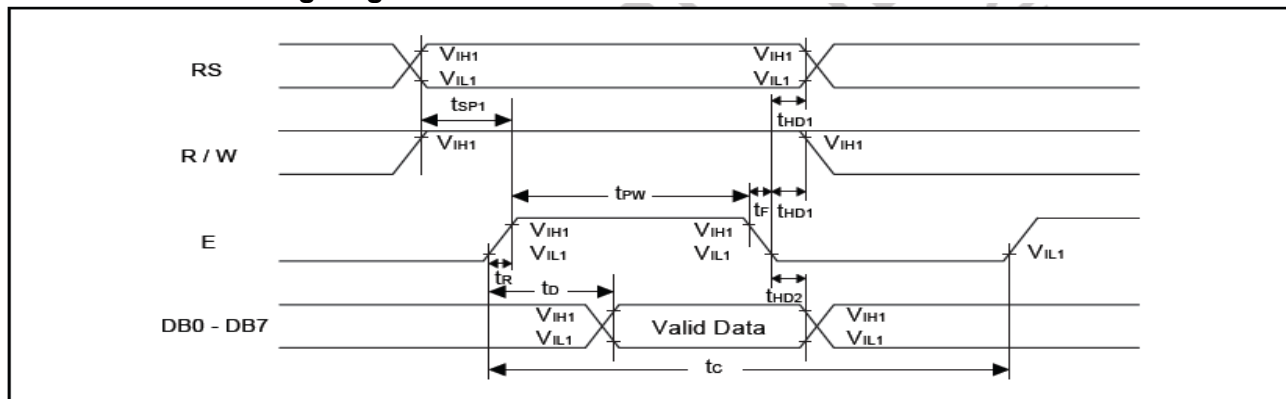

## 6. COMMAND LIST

Instruction	Instruction Code										Description	Execution time (Temp = 25°C)			
	RS	RW	DB7	DB6	DB5	DB4	DB3	DB2	DB1	DB0		Fosc= 190KHz	Fosc= 270KHz	Fosc= 350KHz	
Clear Display	0	0	0	0	0	0	0	0	0	1	Write "20H" to DDRAM and set DDRAM address to "00H" from AC	2.16ms	1.52ms	1.18ms	
Return Home	0	0	0	0	0	0	0	0	0	1	-	Set DDRAM address to "00H" from AC and return cursor to its original position if shifted. The contents of DDRAM are not changed.	2.16ms	1.52ms	1.18ms
Entry Mode Set	0	0	0	0	0	0	0	0	1	I/D	S	Assign cursor moving direction and enable the shift of entire display	53μs	38μs	29μs
Display ON/ OFF Control	0	0	0	0	0	0	0	1	D	C	B	Set display (D), cursor(C), and blinking of cursor(B) on/off control bit.	53μs	38μs	29μs
Cursor or Display Shift	0	0	0	0	0	1	S/C	R/L	-	-	-	Set cursor moving and display shift control bit, and the direction, without changing of DDRAM data.	53μs	38μs	29μs
Function Set	0	0	0	0	1	DL	N	F	-	-	-	Set interface data length (DL: 8-bit/4-bit), numbers of display line (N: 2-line/1-line) and, display font type (F:5x10 dots/5x8 dots)	53μs	38μs	29μs
Set CGRAM Address	0	0	0	1	AC5	AC4	AC3	AC2	AC1	AC0	AC0	Set CGRAM address in address counter.	53μs	38μs	29μs
Set DDRAM Address	0	0	1	AC6	AC5	AC4	AC3	AC2	AC1	AC0	AC0	Set DDRAM address in address counter	53μs	38μs	29μs
Read Busy Flag and Address Counter	0	1	BF	AC6	AC5	AC4	AC3	AC2	AC1	AC0	AC0	Whether during internal operation or not can be known by reading BF. The contents of address counter can also be read.			
Write Data to RAM	1	0	D7	D6	D5	D4	D3	D2	D1	D0	D0	Write data into internal RAM (DDRAM/CGRAM).	53μs	38μs	29μs
Read Data from RAM	1	1	D7	D6	D5	D4	D3	D2	D1	D0	D0	Read data from internal RAM (DDRAM/CGRAM).	53μs	38μs	29μs

## 7.CHARACTER GENERATOR ROM

Upper 4 bit Lower 4 bit	LLLL	LLLH	LLHL	LLHH	LHLL	LHLH	LHHL	LHHH	HLLL	HLLH	HLHL	HLLH	HHLH	HHHL	HHHH
1111				0	1	2	3	4					5	6	7
111H			!	1	A	Q	9	9					。	ア	チ
11HL			"	2	B	R	B	r					「	イ	ウ
11HH			#	3	C	S	C	s					」	ウ	ア
1HLL			*	4	D	T	D	t					「	エ	ト
1HLLH			△	5	E	U	E	u					・	オ	オ
1HHL			△	6	F	V	F	v					ヲ	カ	ニ
1HHH			△	7	G	W	G	w					ヲ	キ	ス
HLLL			○	8	H	X	H	x					ヲ	ク	リ
HLLH			△	9	I	Y	I	y					ウ	ク	ル
HHLH			*	0	J	Z	J	z					エ	コ	シ
HLHH			+	1	K	C	K	c					オ	カ	シ
HLLL			,	2	L	I	L	i					カ	シ	ワ
HLLH			—	3	M	J	M	j					ユ	ス	シ
HHHL			.	4	N	K	N	k					ヨ	セ	ホ
HHHH			/	5	O	L	O	o					ウ	マ	ワ



## 8. QUALITY SPECIFICATIONS

### 8 - 1. LCM Appearance and Electric inspection Condition

1. Inspection will be done by placing LCM 30cm away from inspector's eyeballs under normal illumination.

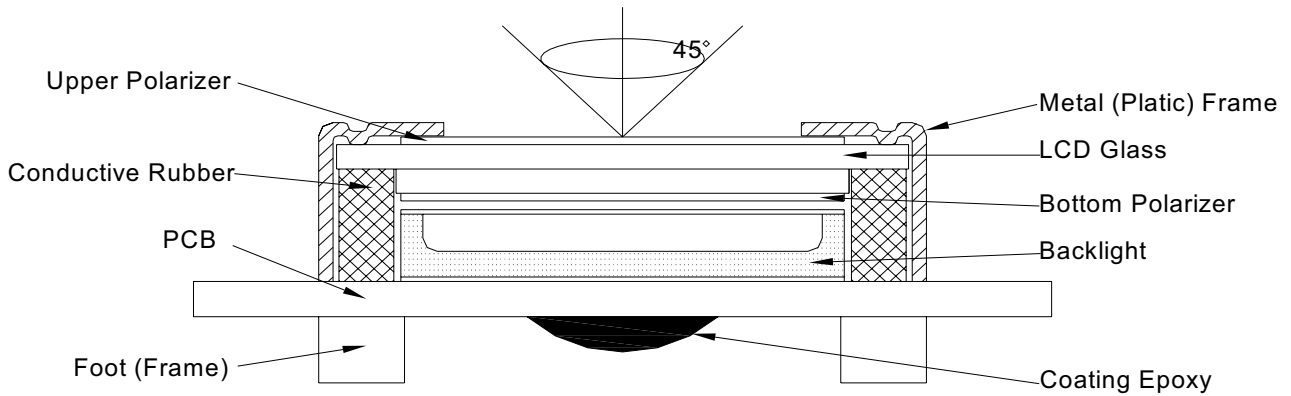

2. View Angle: with in 45° around perpendicular line.

### 8- 2. Definition

#### 1. COB

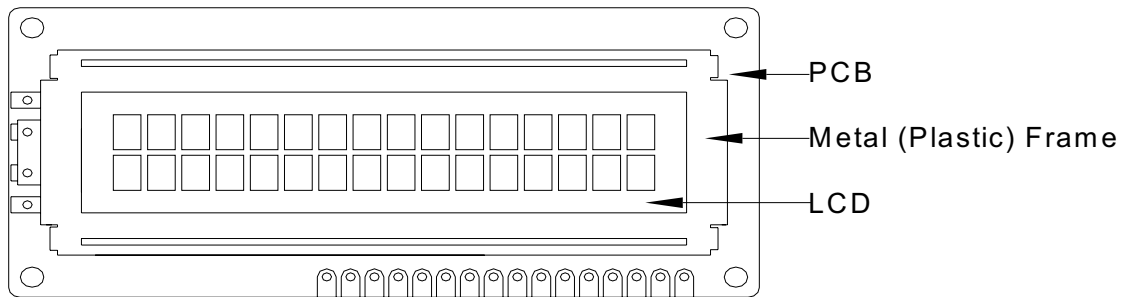

#### 2. Heat Seal

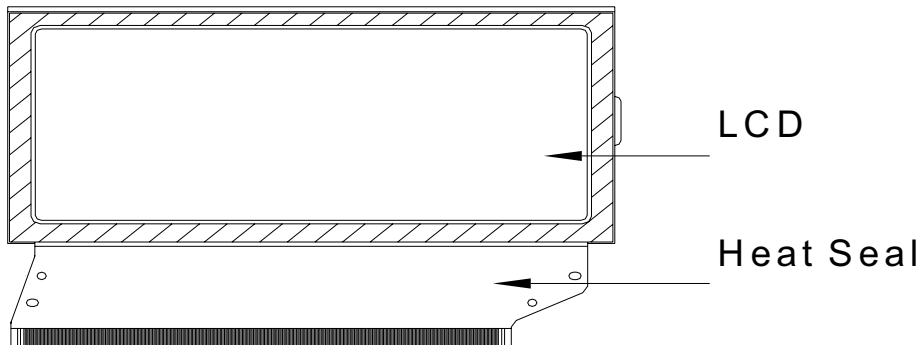

#### 3. TAB and COG

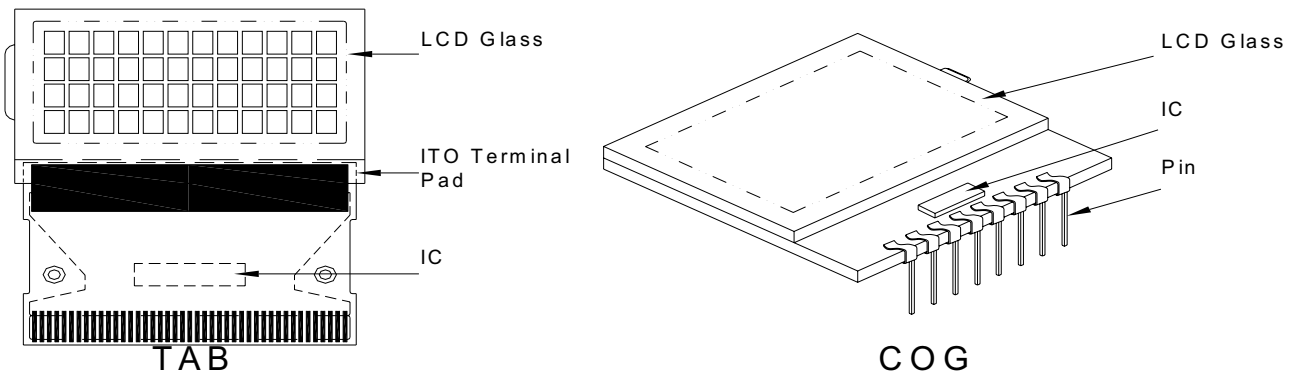

### 8-3. Sampling Plan and Acceptance

#### 1. Sampling Plan

MIL - STD - 105E ( || ) ordinary single inspection is used.

#### 2. Acceptance

Major defect: AQL = 0.25%

Minor defect: AQL = 0.65%

### 8-4. Criteria

#### 1. COB

Defect	Inspection Item	Inspection Standards	
Major	PCB copper flakes peeling off	Any copper flake in viewing Area should be greater than 1.0mm <sup>2</sup>	Reject
Major	Height of coating epoxy	Exceed the dimension of drawing	Reject
Major	Void or hole of coating epoxy	Expose bonding wire or IC	Reject
Major	PCB cutting defect	Exceed the dimension of drawing	Reject

#### 2. SMT

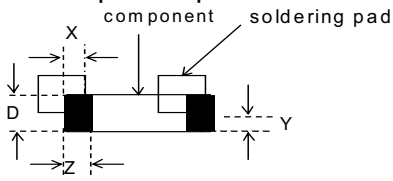
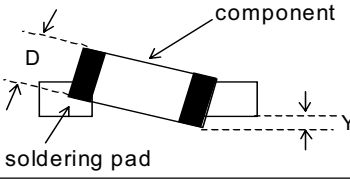
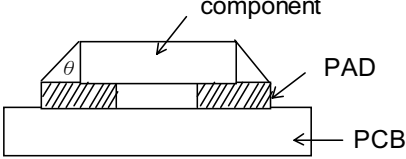
Defect	Inspection Item	Inspection Standards	
Minor	Component marking not readable		Reject
Minor	Component height	Exceed the dimension Of drawing	Reject
Major	Component solder defect (missing , extra, wrong component or wrong orientation)		Reject
Minor	<p>Component position shift</p> 	$X < 3/4Z$ $Y > 1/3D$	Reject Reject
Minor	<p>Component tilt</p> 	$Y > 1/3D$	Reject
Minor	<p>Insufficient solder</p> 	$\theta \leq 20^\circ$	Reject

### 3. Metal (Plastic) Frame

Defect	Inspection Item	Inspection Standards	
Major	Crack / breakage	Anywhere	
Minor	Frame Scratch	W	L
		$w < 0.1\text{mm}$	Any
		$0.1 \leq w < 0.2\text{mm}$	$L \leq 5.0\text{mm}$
		$0.2 \leq w < 0.3\text{mm}$	$L \leq 3.0\text{mm}$
		$w \geq 0.3\text{mm}$	Any
		Note : 1. Above criteria applicable to scratch lines with distance greater than 5mm. 2. Scratch on the back side of frame (not visible) can be ignored .	
Minor	Frame Dent , Prick $\Phi = \frac{L + W}{2}$		Acceptable of Dents / Pricks
		$\Phi \leq 1.0\text{mm}$	2
		$1.0 < \Phi \leq 1.5\text{mm}$	1
		$1.5\text{mm} < \Phi$	0
Note : 1. Above criteria applicable to any two dents / pricks with distance greater than 5mm 2. Dent / prick on the back side of frame (not visible) can be ignored			
Minor	Frame Deformation	Exceed the dimension of drawing	
Minor	Metal Frame Oxidation	Any rust	

### 4. Flexible Film Connector (FFC)

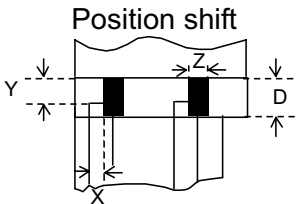
Defect	Inspection Item	Inspection Standards	
Minor	Tilted soldering	Within the angle $+5^\circ$	Acceptable
Minor	Uneven solder joint /bump		Reject
Minor	Hole $\Phi = \frac{L + W}{2}$	Expose the conductive line	Reject
		$\Phi > 1.0\text{mm}$	Reject
Minor		$Y > 1/3D$	Reject
		$X > 1/2Z$	Reject

### 5. Screw

Defect	Inspection Item	Inspection Standards	
Major	Screw missing/loosen		Reject
Minor	Screw oxidation	Any rust	Reject
Minor	Screw deformation	Difficult to accept screw driver	Reject

### 6. Heatseal 、TCP 、FPC

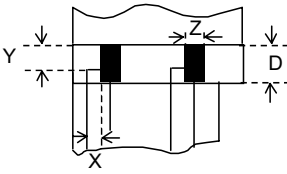
Defect	Inspection Item	Inspection Standards	
Major	Scratch expose conductive layer		Reject
Minor	HS Hole $\Phi = \frac{L + W}{2}$	$\Phi > 0.5\text{mm}$	Reject
Major	Adhesion strength	Less than the specification	Reject
Minor	Position shift 	$Y > 1/3D$	Reject
		$X > 1/2Z$	Reject
Major	Conductive line break		Reject

### 7. LED Backing Protective Film and Others

Defect	Inspection Item	Inspection Standards	
Minor	LED dirty, prick	Acceptable number of units	
		$\Phi \leq 0.10\text{mm}$	Ignore
		$0.10 < \Phi \leq 0.15\text{mm}$	2
		$0.15 < \Phi \leq 0.2\text{mm}$	1
		$\Phi > 0.2\text{mm}$	0
		The distance between any two spots should be $\geq 5\text{mm}$ Any spot/dot/void outside of viewing area is acceptable	
Minor	Protective film tilt	Not fully cover LCD	Reject
Major	COG coating	Not fully cover ITO circuit	Reject

### 8. Electric Inspection

Defect	Inspection Item	Inspection Standards	
Major	Short		Reject
Major	Open		Reject

### 9. Inspection Specification of LCD

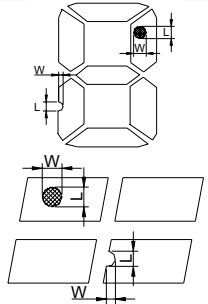
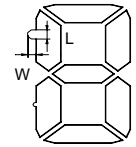
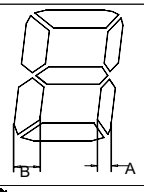
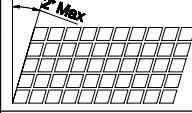
Defect	Inspect Item	Inspection Standards				
		W	$W \leq 0.03$	$0.03 < W \leq 0.05$	$W > 0.05$	
Minor	Linear Defect * Glass Scratch * Polarizer Scratch * Fiber and Linear material	L	$L < 5$	$L < 3$	Any	
		ACC. NO.	1	1	Reject	
		Note	L is the length and W is the width of the defect			
Minor	Black Spot and Polarizer Pricked * Foreign material between glass and polarizer or glass and glass * Polarizer hole or protuberance by external force	$\Phi$	$\Phi \leq 0.1$	$0.1 < \Phi \leq 0.15$	$0.15 < \Phi \leq 0.2$	$\Phi > 0.2$
		ACC. NO.	3EA / 100mm <sup>2</sup>	2	1	0
		Note	$\Phi$ is the average diameter of the defect. Distance between two defects > 10mm.			
Minor	White Spot and Bubble in polarizer * Unobvious transparent foreign material between glass and glass or glass and polarizer * Air protuberance between polarizer and glass	$\Phi$	$\Phi \leq 0.3$	$0.3 < \Phi \leq 0.5$	$0.5 < \Phi$	
		ACC. NO.	3EA / 100mm <sup>2</sup>	1	0	
		Note	$\Phi$ is the average diameter of the defect. Distance between two defects > 10mm.			
Minor	Segment Defect 	$\Phi$	$\Phi \leq 0.10$	$0.10 < \Phi \leq 0.20$	$0.20 < \Phi \leq 0.25$	$\Phi > 0.25$
		ACC. NO.	3EA / 100mm <sup>2</sup>	2	1	0
		Note	W is more than 1/2 segment width			Reject
			$\Phi = \frac{L + W}{2}$ Distance between two defect is 10mm			
Minor	Protuberant Segment  $\Phi = (L + W) / 2$	$\Phi$	$\Phi \leq 0.10$	$0.10 < \Phi \leq 0.20$	$0.20 < \Phi \leq 0.25$	$\Phi > 0.25$
		W	Glue	$W \leq 1/2$ Seg $W \leq 0.2$	$W \leq 1/2$ Seg $W \leq 0.2$	Ignore
		ACC. NO.	3EA / 100mm <sup>2</sup>	2	1	0
Minor	Assembly Mis-alignment  	1. Segment				
		B	$B \leq 0.4\text{mm}$	$0.4 < B \leq 1.0\text{mm}$	$B > 1.0\text{mm}$	
		B-A	$B-A < 1/2B$	$B-A < 0.2$	$B-A < 0.25$	
		Judge	Acceptable	Acceptable	Acceptable	
		2. Dot Matrix				
			Deformation > 2°			Reject
Minor	Stain on LCD Panel Surface	Accept when stains can be wiped lightly with a soft cloth or a similar one. Otherwise, judged according to the above items: "Black spot" and "White Spot"				

## 9. RELIABILITY

NO.	Item	Condition	Criterion
1	High Temperature Operating	70°C , 96Hrs	No defect in cosmetic and operational function allowable.
2	Low Temperature Operating	-20°C , 96Hrs	
3	High Humidity	60°C , 90%RH, 96Hrs	
4	High Temperature Storage	80°C , 96Hrs	
5	Low Temperature Storage	-30°C , 96Hrs	
6	Vibration	Random wave 10 ~ 100Hz Acceleration: 2g 2 Hrs per direction(X,Y,Z)	Total current Consumption should be below double of initial value.
7	Thermal Shock	-20°C to 25°C to 70°C (60Min) (5Min) (60Min) 16Cycles	
8	ESD Testing	Contract Discharge Voltage: +1 ~ 5kV and -1 ~ -5kV  Air Discharge Voltage: +1 ~ 8kV and -1 ~ -8kV	There will be discharged ten times at every discharging voltage cycle. The voltage gap is 1kV.

Note: 1) Above conditions are suitable for our company standard products.  
2) For restrict products, the test conditions listed as above must be revised.

## 10. HANDLING PRECAUTION

### (1) Mounting Method

The panel of the LCD Module consists of two thin glass plates with polarizers which easily get damaged since the Module is fixed by utilizing fitting holes in the printed circuit board. Extreme care should be taken when handling the LCD Modules.

### (2) Caution of LCD handling & cleaning

When cleaning the display surface, use soft cloth with solvent (recommended below) and wipe lightly.

- Isopropyl alcohol
- Ethyl alcohol
- Trichloro trifluro thane

Do not wipe the display surface with dry or hard materials that will damage the polarizer surface.

Do not use the following solvent:

- Water
- Ketone
- Aromatics

### (3) Caution against static charge

The LCD Module use C-MOS LSI drivers, so we recommend that you connect any unused input terminal to VDD or VSS, do not input any signals before power is turned on. And ground your body, Work/assembly table. And assembly equipment to protect against static electricity.

### (4) Packaging

- Modules use LCD elements, and must be treated as such. Avoid intense shock and falls from a height.
- To prevent modules from degradation. Do not operate or store them exposed directly to sunshine or high temperature/humidity.

### (5) Caution for operation

- It is indispensable to drive LCD's within the specified voltage limit since the higher voltage than the limit shorten LCD life. An electrochemical reaction due to direct current causes LCD deterioration, Avoid the use of direct current drive.
- Response time will be extremely delayed at lower temperature than the operating temperature range and on the other hand at higher temperature LCD's show dark color in them. However those phenomena do not mean malfunction or out of order with LCD's. Which will come back in the specified operating temperature range.
- If the display area is pushed hard during operation, some font will be abnormally displayed but it resumes normal condition after turning off once.
- A slight dew depositing on terminals is a cause for electro-chemical reaction resulting in terminal open circuit.

Usage under the relative condition of 40°C, 50%RH or less is reequired.

### (6) Storage

In the case of storing for a long period of time (for instance.) For years) for the purpose or replacement use, The following ways are recommended.

- Storage in a polyethylene bag with sealed so as not to enter fresh air outside in it, And with no desiccant.
- Placing in a dark place where neither exposure to direct sunlight nor light is. Keeping temperature in the specified storage temperature range.
- Storing with no touch on polarizer surface by the anything else. (It is recommended to store them as they have been contained in the inner container at the time of delivery)

### (7) Safety

- It is recommendable to crash damaged or unnecessary LCD into pieces and wash off liquid crystal by using solvents such as acetone and ethanol.

Which should be burned up later.

When any liquid crystal leaked out of a damaged glass cell comes in contact with your hands, please wash it off well with soap and water.

