

LEADER TIME SRL

PRODUCT SPECIFICATION

16*2 Characters COB LCD MODULE MODEL: LT-1602L-902 Ver:1.0

< ◇ > Finally Specification

CUSTOMER'S APPROVAL	
CUSTOMER :	
SIGNATURE:	DATE:

APPROVED BY	PM REVIEWD	PD REVIEWD	PREPARED By

Prepared By:
LEADER TIME SRL
VIA MONS. PROSDOCIMI, 27
36042 BREGANZE (VI)

- This specification is subject to change without notice. Please contact LT or it's representative before designing your product based on this specification.

Table of Contents

No.	Contents	Page
1.	FEATURES	4
2.	MECHANICAL SPECIFICATIONS	4
3.	ELECTRICAL SPECIFICATIONS	4
4.	TERMINAL FUNCTIONS AND BLOCK DIAGRAM	6
5.	TIMING CHARACTERISTICS.....	7
6.	COMMAND LIST.....	8
7.	CHARACTER GENERATOR ROM.....	9
8.	QUALITY SPECIFICATIONS.....	10
9.	RELIABILITY	15
10.	HANDLING PRECAUTION	16
11.	OUTLINE DIMENSION	17

1. Features

The features of LCD are showed as follows

- * Display mode : FSTN/Transmissive/Negative
- * Controller IC : AIP31066(English-Japanese)
- * Display format : 16X2Characters
- * Interface Input Data : 8 bit or 4 bit MPU
- * Driving Method : 1/16Duty, 1/5Bias
- * Viewing Direction :12 O'clock
- * Backlight : LED Unit /White (side)
- * Sample NO. : EC1602K3FVW7B-B0_01/20110526

2. MECHANICAL SPECIFICATIONS

Item	Specification	Unit
Module Size	85(W) x36(H) x9.5MAX(T)	mm
Viewing Area	64.5(W) x 16(H)	mm
Activity Display Area	56.21(W)x11.5(H)	mm
Character Font	5x8 Dots	-
Character Size	2.96(W)x5.56(H)	mm
Character Pitch	3.55(W)x5.94(H)	mm
Dot Size	0.56(W)x0.66(H)	mm

3. ELECTRICAL SPECIFICATIONS

3-1 ABSOLUTE MAXIMUM RATINGS (Ta = 25 °C)

Item	Symbol	Min	Max	Unit
Supply Voltage For Logic	V _{DD}	0.3	7.0	V
Supply Voltage For LCD Drive	V _{LCD}	V _{DD} -15	V _{DD} +0.3	V
Input Voltage	V _{in}	-0.3	V _{DD} +0.3	V
Operating Temp.	T _{op}	-20	+70	°C
Storage Temp.	T _{st}	-30	+80	°C

*. NOTE: The response time will be extremely slow when the operating temperature is around -10°C, and the back ground will become darker at high temperature operating.

3-2 ELECTRICAL CHARACTERISTICS

Item	Symbol	Test Condition	Min.	Typ.	Max.	Unit	
Logic supply Voltage	$V_{DD} - V_{SS}$	$T_a = 25\text{ }^\circ\text{C}$ $V_{DD} = 5\text{V} \pm 10\%$	4.5	5	5.5	V	
LCD Drive	$V_{OP} = V_{DD} - V_0$		3.5	3.8	4.1	V	
Input Voltage	"H" Level		V_{IH}	2.2	-	V_{DD}	V
	"L" Level		V_{IL}	-0.3	-	0.6	V
Frame Frequency	f_{FLM}		-	-	84.4	Hz	
Current Consumption	I_{DD}		-	1.35	-	mA	

3-3 BACKLIGHT

3-3-1. Absolute Maximum Ratings

Item	Symbol	Condition	Min.	Typ.	Max.	Unit
Forward Current	IF	$T_a = 25\text{ }^\circ\text{C}$	-	-	30	mA
Reverse Voltage	VR		-	-	5	V
Power Dissipation	PD		-	-	93	mW

3-3-2. Electrical-optical Characteristics

Item	Symbol	Condition	Min.	Typ.	Max.	Unit									
Forward Voltage	VF	$I_f = 30\text{mA}$ $T_a = 25\text{ }^\circ\text{C}$	-	3.1	-	V									
Average Luminous Intensity	Iv		150	-	-	cd/m ²									
Color Coordinates	-		<table border="1"> <tr> <td>X</td><td>Y</td><td>X</td><td>Y</td><td>X</td><td>Y</td> </tr> <tr> <td>0.25</td><td>0.25</td><td>0.28</td><td>0.28</td><td>0.31</td><td>0.31</td> </tr> </table>	X	Y	X	Y	X	Y	0.25	0.25	0.28	0.28	0.31	0.31
X	Y	X	Y	X	Y										
0.25	0.25	0.28	0.28	0.31	0.31										

The brightness is measured without LCD panel

For operation above 25 °C, The I_{fm} & P_d must be derated, the current derating is -0.36mA/ °C for DC drive and -0.86mA/ °C for Pulse drive, the Power dissipation is -0.75mW/ °C. The product working current must not more than the 60% of the I_{fm} or I_{fp} according to the working temperature.

4. TERMINAL FUNCTIONS AND BLOCK DIAGRAM

4-1 INTERFACE PIN FUNCTION DESCRIPTION

PIN NO.	SYMBOL	FUNCIONS
1	VSS	Ground
2	VDD	Supply voltage for logical circuit
3	V0	Supply voltage for LCD driving
4	RS	A signal for selecting registers. 1: Data Register (for read and write) 0: Instruction Register (for write)
5	R/W	A signal for selecting read or write actions.1: Read, 0: Write.
6	E	A enable signal for reading or writing data.
7-14	DB0~DB7	8 Bit Data Bus
15	A	Backlight (5.0V)
16	K	Backlight (-)

4-2 BLOCK DIAGRAM

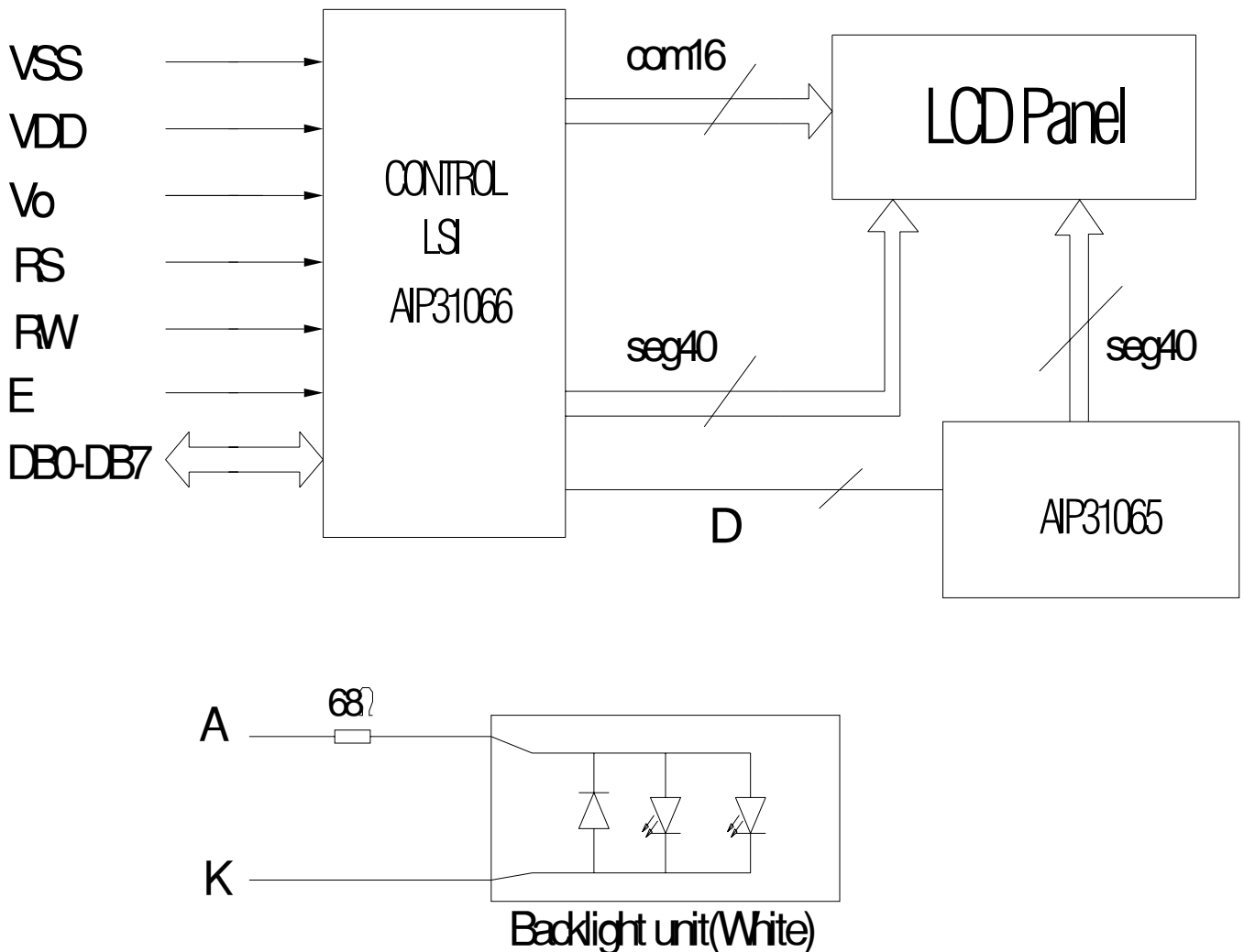

5. TIMING CHARACTERISTICS

5 - 1 Write mode

Mode	Characteristic	Symbol	Min.	Typ.	Max.	Unit
Write Mode (Refer to Fig-1)	E Cycle Time	t_c	500	-	-	ns
	E Rise / Fall Time	t_R, t_F	-	-	20	
	E Pulse Width (High, Low)	t_w	230	-	-	
	R/W and RS Setup Time	t_{su1}	40	-	-	
	R/W and RS Hold Time	t_{H1}	10	-	-	
	Data Setup Time	t_{su2}	80	-	-	
	Data Hold Time	t_{H2}	10	-	-	

5-2 Write mode timing diagram

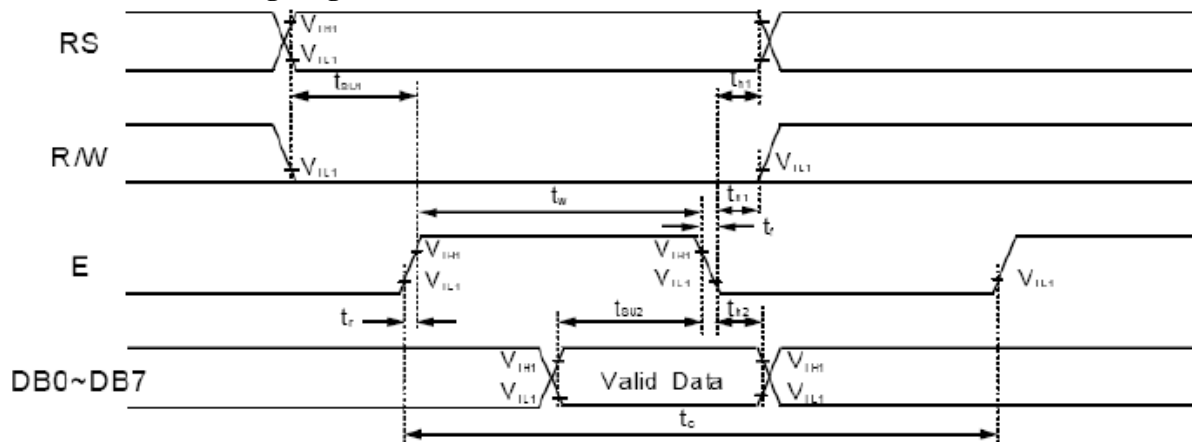

5.3 Read mode

Read Mode (Refer to Fig-2)	E Cycle Time	t_c	500	-	-	ns
	E Rise / Fall Time	t_R, t_F	-	-	20	
	E Pulse Width (High, Low)	t_w	230	-	-	
	R/W and RS Setup Time	t_{su}	40	-	-	
	R/W and RS Hold Time	t_H	10	-	-	
	Data Output Delay Time	t_D	-	-	120	
	Data Hold Time	t_{DH}	5	-	-	

5-4 Read mode timing diagram

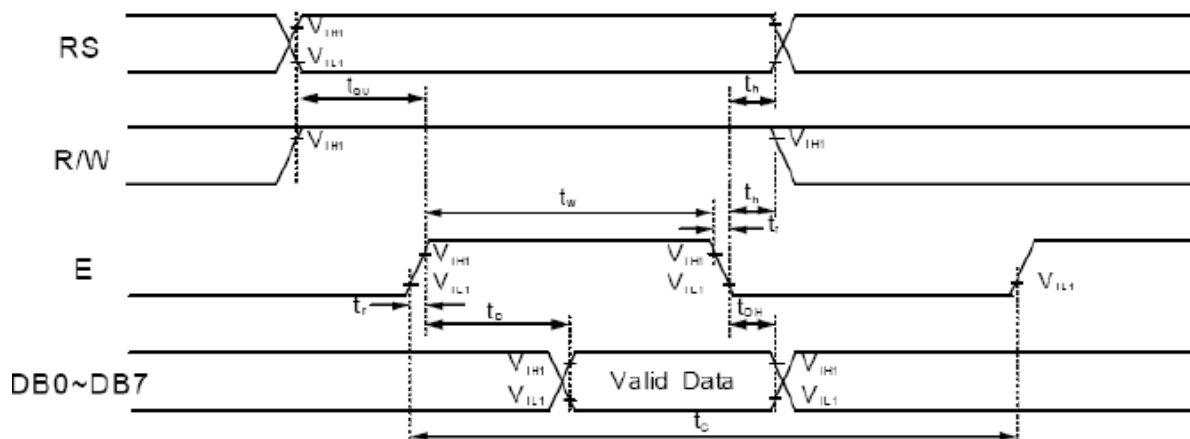

6. COMMAND LIST

Instruction	Instruction Code										Description	Execution time (fosc=270 kHz)	
	RS	R/W	DB7	DB6	DB5	DB4	DB3	DB2	DB1	DB0			
Clear Display	0	0	0	0	0	0	0	0	0	1	Write "20H" to DDRAM and set DDRAM address to "00H" from AC	1.53 ms	
Return Home	0	0	0	0	0	0	0	0	0	1	-	Set DDRAM address to "00H" from AC and return cursor to its original position if shifted. The contents of DDRAM are not changed.	1.53 ms
Entry Mode Set	0	0	0	0	0	0	0	0	1	I/D	SH	Assign cursor moving direction and enable the shift of entire display.	39 μs
Display ON/OFF Control	0	0	0	0	0	0	0	1	D	C	B	Set display(D), cursor(C), and blinking of cursor(B) on/off control bit.	39 μs
Cursor or Display Shift	0	0	0	0	0	0	1	S/C	R/L	-	-	Set cursor moving and display shift control bit, and the direction, without changing of DDRAM data.	39 μs
Function Set	0	0	0	0	0	1	DL	N	F	-	-	Set interface data length (DL: 8-bit/4-bit), numbers of display line (N: 2-line/1-line) and, display font type (F:5×11dots/5×8 dots)	39 μs
Set CGRAM Address	0	0	0	1	AC5	AC4	AC3	AC2	AC1	AC0		Set CGRAM address in address counter.	39 μs
Set DDRAM Address	0	0	1	AC6	AC5	AC4	AC3	AC2	AC1	AC0		Set DDRAM address in address counter.	39 μs
Read Busy Flag and Address	0	1	BF	AC6	AC5	AC4	AC3	AC2	AC1	AC0		Whether during internal operation or not can be known by reading BF. The contents of address counter can also be read.	0 μs
Write Data to RAM	1	0	D7	D6	D5	D4	D3	D2	D1	D0		Write data into internal RAM (DDRAM/CGRAM).	43 μs
Read Data from RAM	1	1	D7	D6	D5	D4	D3	D2	D1	D0		Read data from internal RAM (DDRAM/CGRAM).	43 μs

* -: dont care

NOTE: When an MPU program with checking the Busy Flag(DB7) is made, it must be necessary 1/2Fosc is necessary for executing the next instruction by the falling edge of the 'E' signal after the Busy Flag (DB7) goes to "Low".

7. CHARACTER GENERATOR ROM

Upper 4 Bits Lower 4 Bits	0000	0001	0010	0011	0100	0101	0110	0111	1000	1001	1010	1011	1100	1101	1110	1111
xxxx0000	CG RAM (1)			0	a	P	'	F				-	タ	ミ	α	ρ
xxxx0001	(2)		!	1	A	Q	a	q			。	ア	チ	△	ä	q
xxxx0010	(3)		"	2	B	R	b	r			「	イ	ツ	×	β	θ
xxxx0011	(4)		#	3	C	S	c	s			」	ウ	テ	ε	ε	∞
xxxx0100	(5)		\$	4	D	T	d	t			、	エ	ト	†	μ	∞
xxxx0101	(6)		%	5	E	U	e	u			・	オ	ナ	∟	ε	ü
xxxx0110	(7)		&	6	F	V	f	v			ヲ	カ	ニ	ヨ	ρ	Σ
xxxx0111	(8)		'	7	G	W	g	w			フ	キ	ヌ	ラ	g	π
xxxx1000	(1)		(8	H	X	h	x			イ	ク	ネ	リ	μ	×
xxxx1001	(2))	9	I	Y	i	y			ウ	ケ	ル		'	∫
xxxx1010	(3)		*	:	J	Z	j	z			エ	コ	∩	∨	j	≠
xxxx1011	(4)		+	;	K	L	k	l			オ	サ	ヒ	ロ	*	π
xxxx1100	(5)		,	<	L	¥	l	l			カ	シ	フ	ワ	φ	π
xxxx1101	(6)		-	=	M	l	m	}			ユ	ス	∧	∩	ε	÷
xxxx1110	(7)		.	>	N	^	n	‡			ヨ	セ	ホ	”	π	
xxxx1111	(8)		/	?	O	_	o	†			ツ	ソ	マ	°	ö	■

Note: The user can specify any pattern for character-generator RAM.

8. QUALITY SPECIFICATIONS

8 - 1. LCM Appearance and Electric inspection Condition

1. Inspection will be done by placing LCM 30cm away from inspector's eyeballs under normal illumination.

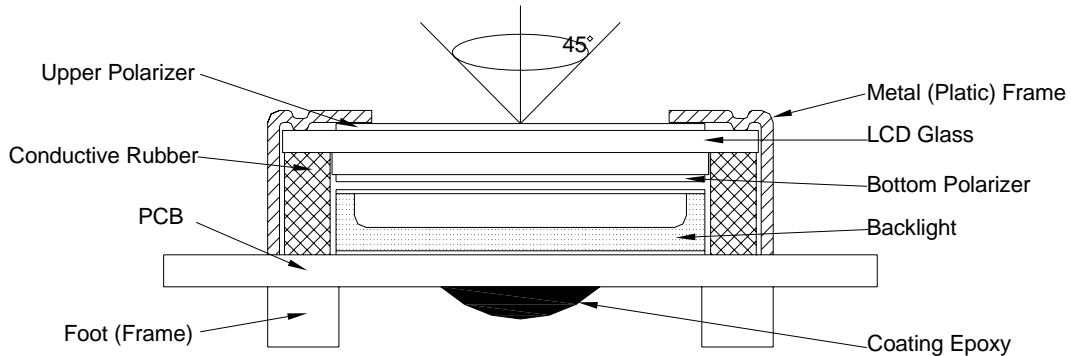

2. View Angle: with in 45° around perpendicular line.

8- 2. Definition

1. COB

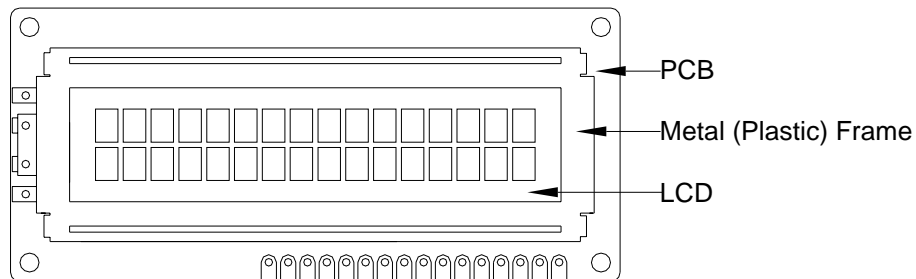

2. Heat Seal

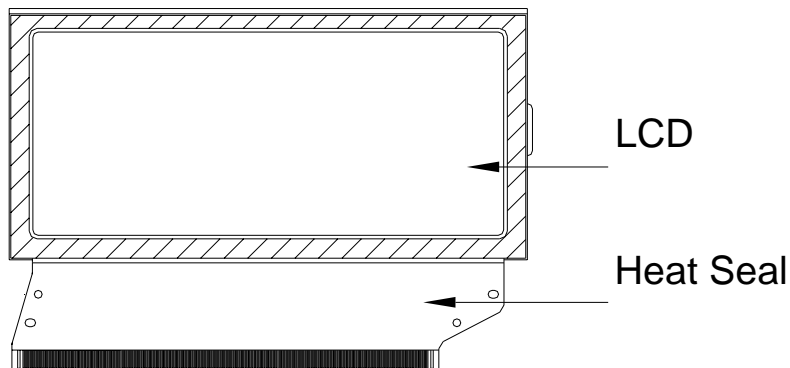

3. TAB and COG

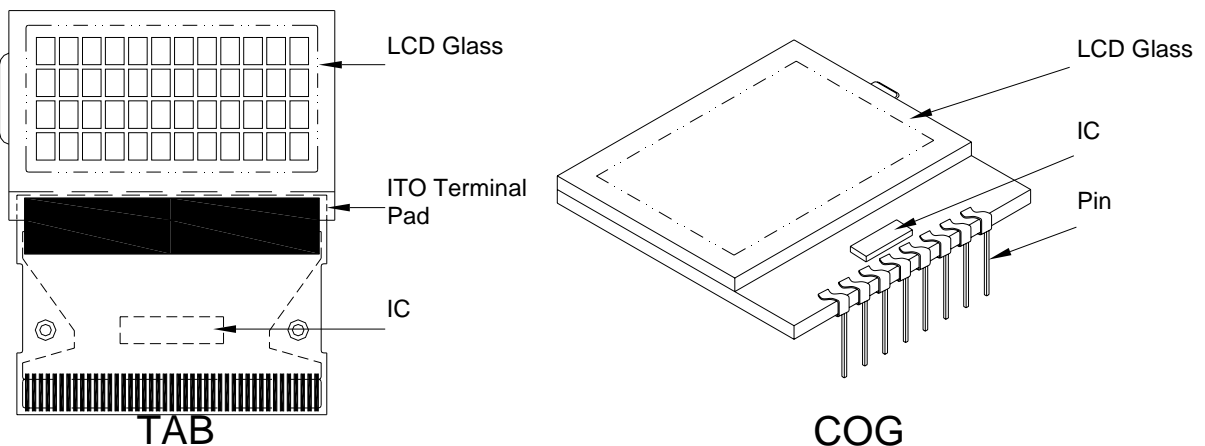

8-3. Sampling Plan and Acceptance

1. Sampling Plan

MIL - STD - 105E (||) ordinary single inspection is used.

2. Acceptance

Major defect: AQL = 0.65%

Minor defect: AQL = 1.5%

8-4. Criteria

1. COB

Defect	Inspection Item	Inspection Standards	
Major	PCB copper flakes peeling off	Any copper flake in viewing Area should be greater than 1.0mm ²	Reject
Major	Height of coating epoxy	Exceed the dimension of drawing	Reject
Major	Void or hole of coating epoxy	Expose bonding wire or IC	Reject
Major	PCB cutting defect	Exceed the dimension of drawing	Reject

2. SMT

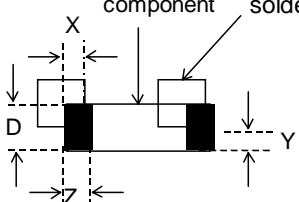
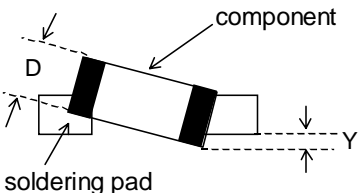
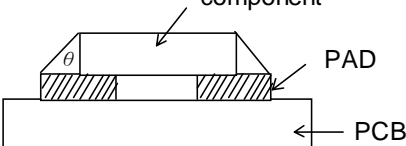
Defect	Inspection Item	Inspection Standards	
Minor	Component marking not readable		Reject
Minor	Component height	Exceed the dimension Of drawing	Reject
Major	Component solder defect (missing , extra, wrong component or wrong orientation)		Reject
Minor	<p>Component position shift</p> 	$X < 3/4Z$ $Y > 1/3D$	Reject
Minor	<p>Component tilt</p> 	$Y > 1/3D$	Reject
Minor	<p>Insufficient solder</p> 	$\theta \leq 20^\circ$	Reject

3. Metal (Plastic) Frame

Defect	Inspection Item	Inspection Standards		
Major	Crack / breakage	Anywhere		Reject
Minor	Frame Scratch	W	L	Acceptable of Scratch
		$w < 0.1\text{mm}$	Any	Ignore
		$0.1 \leq w < 0.2\text{mm}$	$L \leq 5.0\text{mm}$	2
		$0.2 \leq w < 0.3\text{mm}$	$L \leq 3.0\text{mm}$	1
		$w \geq 0.3\text{mm}$	Any	0
		Note: 1. Above criteria applicable to scratch lines with distance greater than 5mm. 2. Scratch on the back side of frame (not visible) can be ignored.		
Minor	Frame Dent , Prick $\Phi = \frac{L + W}{2}$			Acceptable of Dents / Pricks
		$\Phi \leq 1.0\text{mm}$		2
		$1.0 < \Phi \leq 1.5\text{mm}$		1
		$1.5\text{mm} < \Phi$		0
		Note : 1. Above criteria applicable to any two dents / pricks with distance greater than 5mm 2. Dent / prick on the back side of frame (not visible) can be ignored		
Minor	Frame Deformation	Exceed the dimension of drawing		
Minor	Metal Frame Oxidation	Any rust		

4. Flexible Film Connector (FFC)

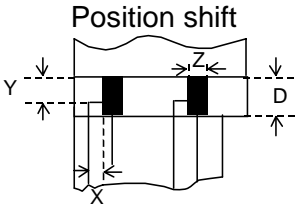
Defect	Inspection Item	Inspection Standards	
Minor	Tilted soldering	Within the angle $+5^\circ$	Acceptable
Minor	Uneven solder joint /bump		Reject
Minor	Hole $\Phi = \frac{L + W}{2}$	Expose the conductive line	Reject
		$\Phi > 1.0\text{mm}$	Reject
Minor	 <p>Position shift</p>	$Y > 1/3D$	Reject
		$X > 1/2Z$	Reject

5. Screw

Defect	Inspection Item	Inspection Standards	
Major	Screw missing/loosen		Reject
Minor	Screw oxidation	Any rust	Reject
Minor	Screw deformation	Difficult to accept screw driver	Reject

6. Heatseal 、TCP 、FPC

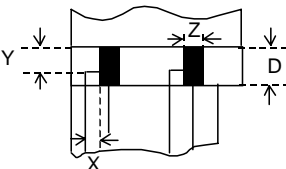
Defect	Inspection Item	Inspection Standards	
Major	Scratch expose conductive layer		Reject
Minor	HS Hole $\Phi = \frac{L+W}{2}$	$\Phi > 0.5\text{mm}$	Reject
Major	Adhesion strength	Less than the specification	Reject
Minor	Position shift 	$Y > 1/3D$	Reject
		$X > 1/2Z$	Reject
Major	Conductive line break		Reject

7. LED Backing Protective Film and Others

Defect	Inspection Item	Inspection Standards	
Minor	LED dirty, prick	Acceptable number of units	
		$\Phi \leq 0.10\text{mm}$	ignore
		$0.10 < \Phi \leq 0.15\text{mm}$	2
		$0.15 < \Phi \leq 0.2\text{mm}$	1
		$\Phi > 0.2\text{mm}$	0
		The distance between any two spots should be $\geq 5\text{mm}$ Any spot/dot/void outside of viewing area is acceptable	
Minor	Protective film tilt	Not fully cover LCD	Reject
Major	COG coating	Not fully cover ITO circuit	Reject

8. Electric Inspection

Defect	Inspection Item	Inspection Standards	
Major	Short		Reject
Major	Open		Reject

9. Inspection Specification of LCD

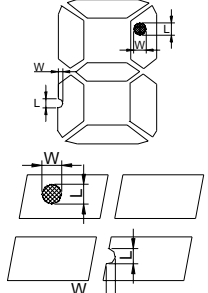
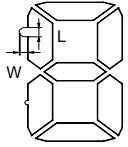
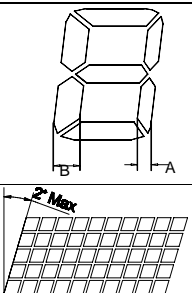
Defect	Inspect Item	Inspection Standards				
Minor	Linear Defect * Glass Scratch * Polarizer Scratch * Fiber and Linear material	W	$W \leq 0.03$	$0.03 < W \leq 0.05$	$W > 0.05$	
		L	$L < 5$	$L < 3$	Any	
		ACC. NO.	1	1	Reject	
		Note	L is the length and W is the width of the defect			
Minor	Black Spot and Polarizer Pricked * Foreign material between glass and polarizer or glass and glass * Polarizer hole or protuberance by external force	Φ	$\Phi \leq 0.1$	$0.1 < \Phi \leq 0.15$	$0.15 < \Phi \leq 0.2$	$\Phi > 0.2$
		ACC. NO.	3EA / 100mm ²	2	1	0
		Note	Φ is the average diameter of the defect. Distance between two defects > 10mm.			
Minor	White Spot and Bubble in polarizer * Unobvious transparent foreign material between glass and glass or glass and polarizer * Air protuberance between polarizer and glass	Φ	$\Phi \leq 0.3$	$0.3 < \Phi \leq 0.5$	$0.5 < \Phi$	
		ACC. NO.	3EA / 100mm ²	1	0	
		Note	Φ is the average diameter of the defect. Distance between two defects > 10mm.			
Minor	Segment Defect 	Φ	$\Phi \leq 0.10$	$0.10 < \Phi \leq 0.20$	$0.20 < \Phi \leq 0.25$	$\Phi > 0.25$
		ACC. NO.	3EA / 100mm ²	2	1	0
		Note	W is more than 1/2 segment width			Reject
		Note	$\Phi = \frac{L + W}{2}$ Distance between two defect is 10mm			
Minor	Protuberant Segment  $\Phi = (L + W) / 2$	Φ	$\Phi \leq 0.10$	$0.10 < \Phi \leq 0.20$	$0.20 < \Phi \leq 0.25$	$\Phi > 0.25$
		W	Glue	$W \leq 1/2$ Seg $W < 0.2$	$W \leq 1/2$ Seg $W < 0.2$	Ignore
		ACC. NO.	3EA / 100mm ²	2	1	0
Minor	Assembly Mis-alignment 	1. Segment				
		B	$B \leq 0.4\text{mm}$	$0.4 < B \leq 1.0\text{mm}$	$B > 1.0\text{mm}$	
		B-A	$B-A < 1/2B$	$B-A < 0.2$	$B-A < 0.25$	
		Judge	Acceptable	Acceptable	Acceptable	
		2. Dot Matrix				
Deformation > 2°				Reject		
Minor	Stain on LCD Panel Surface	Accept when stains can be wiped lightly with a soft cloth or a similar one. Otherwise, judged according to the above items: "Black spot" and "White Spot"				

9. RELIABILITY

NO.	Item	Condition	Criterion
1	High Temperature Operating	70°C , 96Hrs	No defect in cosmetic and operational function allowable. Total current Consumption should be below double of initial value.
2	Low Temperature Operating	-20°C , 96Hrs	
3	High Humidity	50°C , 90%RH, 96Hrs	
4	High Temperature Storage	80°C , 96Hrs	
5	Low Temperature Storage	-30°C , 96Hrs	
6	Vibration	Random wave 10 ~ 100Hz Acceleration: 2g 2 Hrs per direction(X,Y,Z)	
7	Thermal Shock	-20°C to 25°C to 70°C (60Min) (5Min) (60Min) 16Cycles	
8	ESD Testing	Contract Discharge Voltage: +1 ~ 5kV and -1 ~ -5kV Air Discharge Voltage: +1 ~ 8kV and -1 ~ -8kV	

Note: 1) Above conditions are suitable for our company standard products.
2) For restrict products, the test conditions listed as above must be revised.

10. HANDLING PRECAUTION

(1) Mounting Method

The panel of the LCD Module consists of two thin glass plates with polarizers, which easily get damaged since the Module is fixed by utilizing fitting holes in the printed circuit board. Extreme care should be taken when handling the LCD Modules.

(2) Caution of LCD handling & cleaning

When cleaning the display surface, use soft cloth with solvent (recommended below) and wipe lightly.

- Isopropyl alcohol
- Ethyl alcohol
- Tricolor trifler thane

Do not wipe the display surface with dry or hard materials that will damage the polarizer surface.

Do not use the following solvent:

- Water
- Kenton
- Aromatics

(3) Caution against static charge

The LCD Module use C-MOS LSI drivers, so we recommend that you connect any unused input terminal to VDD or VSS, do not input any signals before power is turned on. And ground your body, Work/assembly table. And assembly equipment to protect against static electricity.

(4) Packaging

- Modules use LCD elements, and must be treated as such. Avoid intense shock and falls from a height.
- To prevent modules from degradation. Do not operate or store them exposed directly to sunshine or high temperature/humidity.

(5) Caution for operation

- It is indispensable to drive LCD's within the specified voltage limit since the higher voltage than the limit shorten LCD life. An electrochemical reaction due to direct current causes LCD deterioration, Avoid the use of direct current drive.
- Response time will be extremely delayed at lower temperature than the operating temperature range and on the other hand at higher temperature LCD's show dark color in them. However those phenomena do not mean malfunction or out of order with LCD's .which will come back in the specified operating temperature range.
- If the display area is pushed hard during operation, some font will be abnormally displayed but it resumes normal condition after turning off once.
- A slight dew depositing on terminals is a cause for electro-chemical reaction resulting in terminal open circuit.

Usage under the relative condition of 40°C, 50%RH or less is required.

(6) Storage

In the case of storing for a long period of time, (For years) for the purpose or replacement use, the following ways are recommended.

- Storage in a polyethylene bag with sealed so as not to enter fresh air outside in it, And with no desiccant.
- Placing in a dark place where neither exposure to direct sunlight nor light is. Keeping temperature in the specified storage temperature range.
- Storing with no touch on polarizer surface by the anything else. (It is recommended to store them as they have been contained in the inner container at the time of delivery)

(7) Safety

- It is recommendable to crash damaged or unnecessary LCD into pieces and wash off liquid crystal by using solvents such as acetone and ethanol. Which should be burned up later. When any liquid crystal leaked out of a damaged glass cell comes in contact with your hands, please wash it off well with soap and water.

11. OUTLINE DIMENSION

