

PRODUCT SPECIFICATION

MONO LCD MODULE MODEL: G1206T2FSW6B-B0 Ver:1.0

<◇> Preliminary Specification

<◆> Finally Specification

CUSTOMER'S APPROVAL	
CUSTOMER :	
SIGNATURE:	DATE:

APPROVED BY	PM REVIEWED	PD REVIEWED	PREPARED BY
冯学亮 2012.3.20	邓臣德 2012.3.19	齐科 2012.3.19	周福云

Table of Contents

No.	Contents	Page
1.	FEATURES	4
2.	MECHANICAL SPECIFICATIONS.....	4
3.	ELECTRICAL SPECIFICATIONS	4
4.	TERMINAL FUNCTIONS AND BLOCK DIAGRAM	6
5.	TIMING CHARACTERISTICS.....	7
6.	INSTRUCTION SET.....	9
7.	QUALITY SPECIFICATIONS.....	11
8.	RELIABILITY	16
9.	HANDLING PRECAUTION	17
10.	OUTLINE DIMENSION	18

1. Features

The features of LCD are as follows

- * Display mode : FSTN /Transflective/Positive
- * Drive IC : SBN6400G & SBN0064G
- * Interface : 8bit-6800 Series
- * Driving Method : 1/64 Duty, 1/9 Bias
- * Viewing Direction : 6 O'clock
- * Backlight : LED/white
- * Sample NO. : G1206T2FSW6B-B0_01/20120316

2. MECHANICAL SPECIFICATIONS

Item	Specification	Unit
Module Size	93 (W)×70(H)×13.6MAX(D)	mm
Number of Dots	128× 64 Dots	-
View display area	72(W)× 40 (H)	mm
Activity Display Area	66.52(W)× 33.24(H)	mm
Dot Size	0.48(W)× 0.48(H)	mm
Dot Pitch	0.52(W)× 0.52(H)	mm

3. ELECTRICAL SPECIFICATIONS

3-1 ABSOLUTR MAZIMUM RATINGS (Ta = 25 °C)

Item	Symbol	Standard Value			Unit
		Min.	Typ.	Max.	
Supply Voltage For Logic	V _{DD}	-0.3	-	7.0	V
Supply Voltage For LCD Drive	V _{LCD}	0	-	+13	V
Input Voltage	V _{in}	-0.3	-	V _{DD} +0.3	V
Operating Temp.	Top	-20	-	+70	°C
Storage Temp.	Tst	-30	-	+80	°C

*. NOTE: The response time will be extremely slow when the operating temperature is around -10°C, and the back ground will become darker at high temperature operating.

3-2 ELECTRICAL CHARACTERISTICS

Item	Symbol	Test Condition	Min.	Typ.	Max.	Unit	
Logic supply Voltage	$V_{DD} - V_{SS}$	$T_a = 25\text{ }^\circ\text{C}$ $V_{DD}=5.0\text{V} \pm 5\%$	4.5	5.0	5.5	V	
LCD Drive	V_{LCD}		8.7	9.0	9.3	V	
Input Voltage	"H" Level		V_{IH}	0	-	0.8	V
	"L" Level		V_{IL}	$V_{DD}-2.2$	-	V_{DD}	V
Frame Frequency	f_{FLM}		-	70	-	Hz	
Current Consumption	I_{DD}		-	5.04	-	mA	

3-3. BACKLIGHT

3-3-1. Absolute Maximum Ratings

Item	Symbol	Condition	Min.	Typ.	Max.	Unit
Forward Current	IF	$T_a = 25\text{ }^\circ\text{C}$	-	60	80	mA
Reverse Voltage	VR		-	-	5	V
Power Dissipation	PD		-	-	330	mW

3-3-2. Electrical-optical Characteristics

Item	Symbol	Condition	Min.	Typ.	Max.	Unit
Forward Voltage	VF	$I_f=60\text{mA}$ $T_a = 25\text{ }^\circ\text{C}$	-	3.3	-	V
Luminous Intensity	I_v		400	-	-	cd/m^2
Color coordinate	X		0.25	0.28	0.31	-
	Y	0.25	0.28	0.31		

The brightness is measured without LCD panel

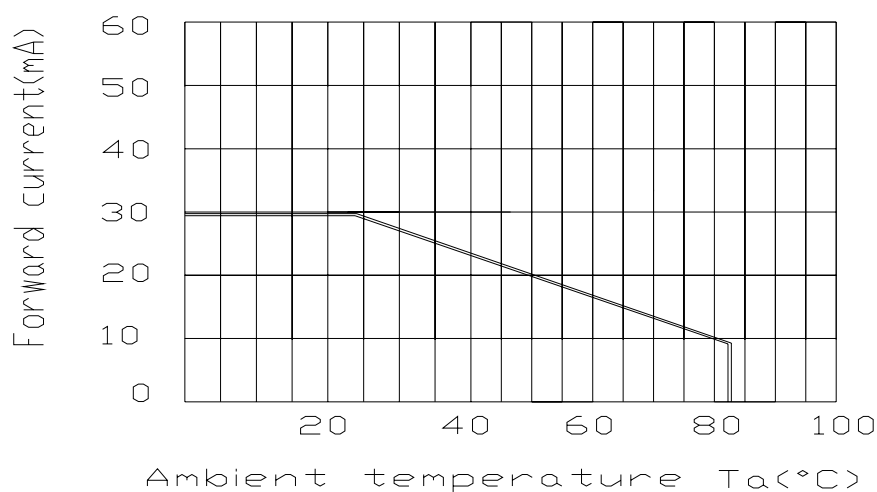

For operation above 25 $^\circ\text{C}$, The I_{fm} & P_d must be derated, the current derating is $-0.36\text{mA}/^\circ\text{C}$ for DC drive and $-0.86\text{mA}/^\circ\text{C}$ for Pulse drive, the Power dissipation is $-0.75\text{mW}/^\circ\text{C}$. The product working current must not more than the 60% of the I_{fm} or I_{fp} according to the working temperature.

4. TERMINAL FUNCTIONS AND BLOCK DIAGRAM

4-1. INTERFACE PIN FUNCTION DESCRIPTION

PIN NO.1	SYMBOL	FUNCIONS
1	VSS	Ground (0V)
2	VDD	Supply voltage for logical circuit
3	V0	Supply voltage for LCD driving
4	D/I	Date/Instruction register select
5	R/W	Read write control
6	E	Enable
7-14	DB0-DB7	Data bus line
15	CS1	Chip Selection, active high
16	CS2	Chip Selection, active high
17	RES	Reset signal
18	Vout	Voltage for LCD drive
19	A	Backlight (+5.0V)
20	K	Backlight (-)

4-2. BLOCK DIAGRAM

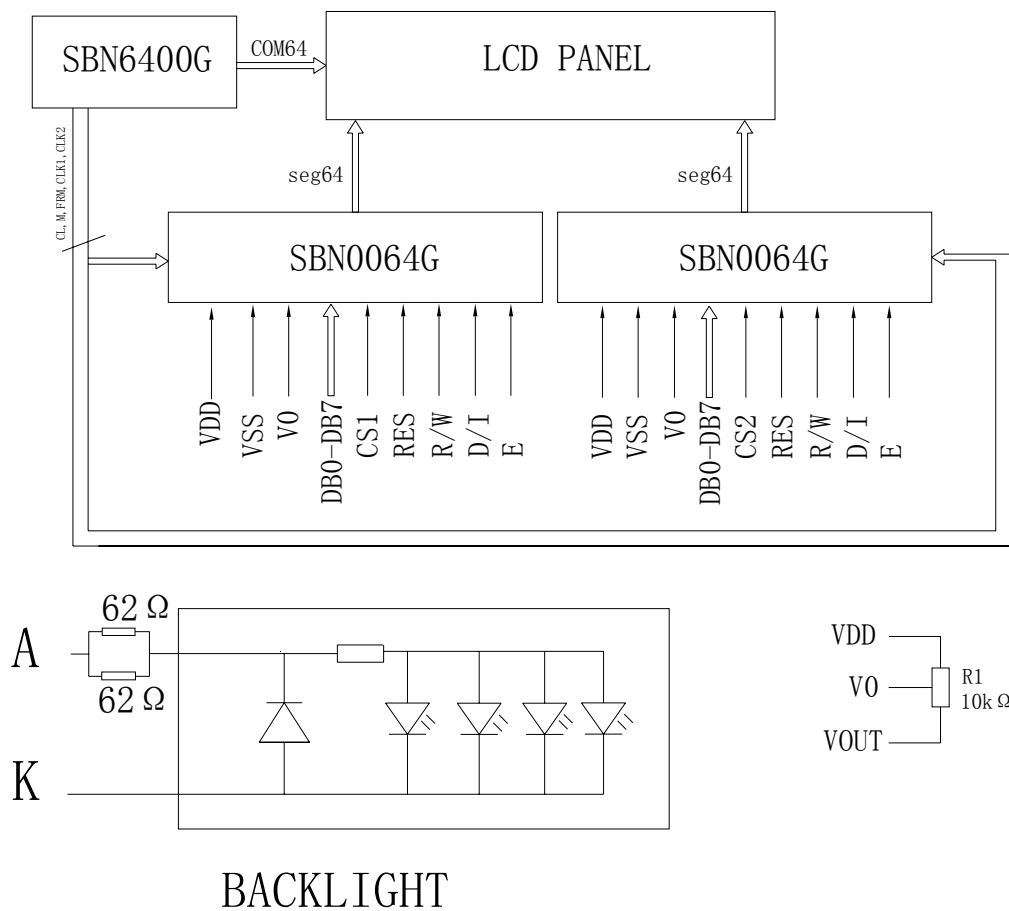

5. TIMING CHARACTERISTICS

5-1. Microcontroller interface timing for writing to the SBN0064G

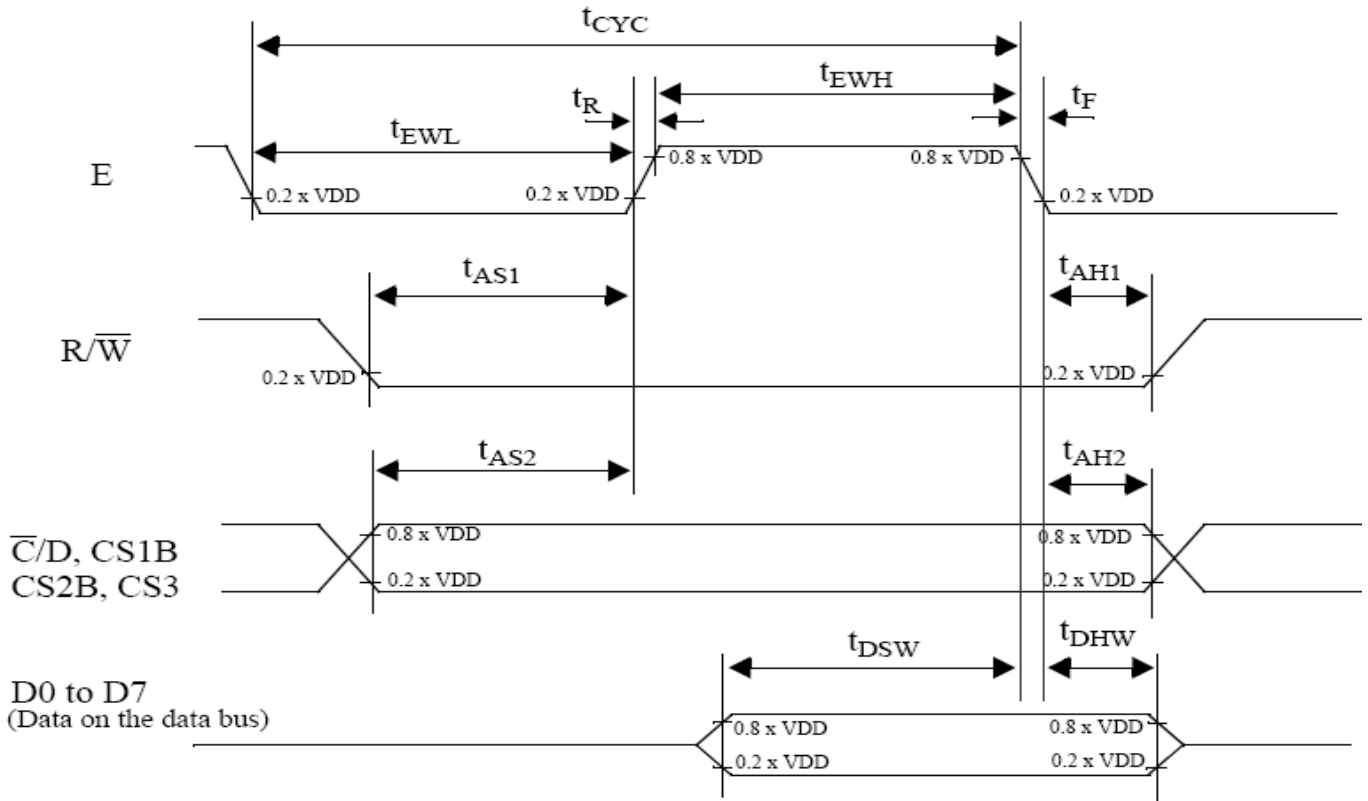

$V_{DD} = 5 V \pm 10\%$; $V_{SS} = 0 V$; $T_{amb} = -20\text{ }^{\circ}\text{C}$ to $+75\text{ }^{\circ}\text{C}$.

symbol	parameter	min.	max.	test conditions	unit
t_{CYC}	Enable (E) cycle time	1000			ns
t_{EWL}	Enable (E) LOW width	450			
t_{EWH}	Enable (E) HIGH width	450			
t_R	Enable (R) rise time		20		
t_F	Enable (F) fall time		20		
t_{AS1}	Write set-up time	140			
t_{AH1}	Write hold time	10			
t_{AS2}	C/D, CS1B, CS2B, CS3 set-up time	140			
t_{AH2}	C/D, CS1B, CS2B, CS3 hold time	10			
t_{DSW}	Data setup time (on the data bus)	200		The loading on the data bus is shown in Fig. 18.	
t_{DHW}	Data hold time (on the data bus)	10			

5-2. Microcontroller interface timing for reading from the SBN0064G

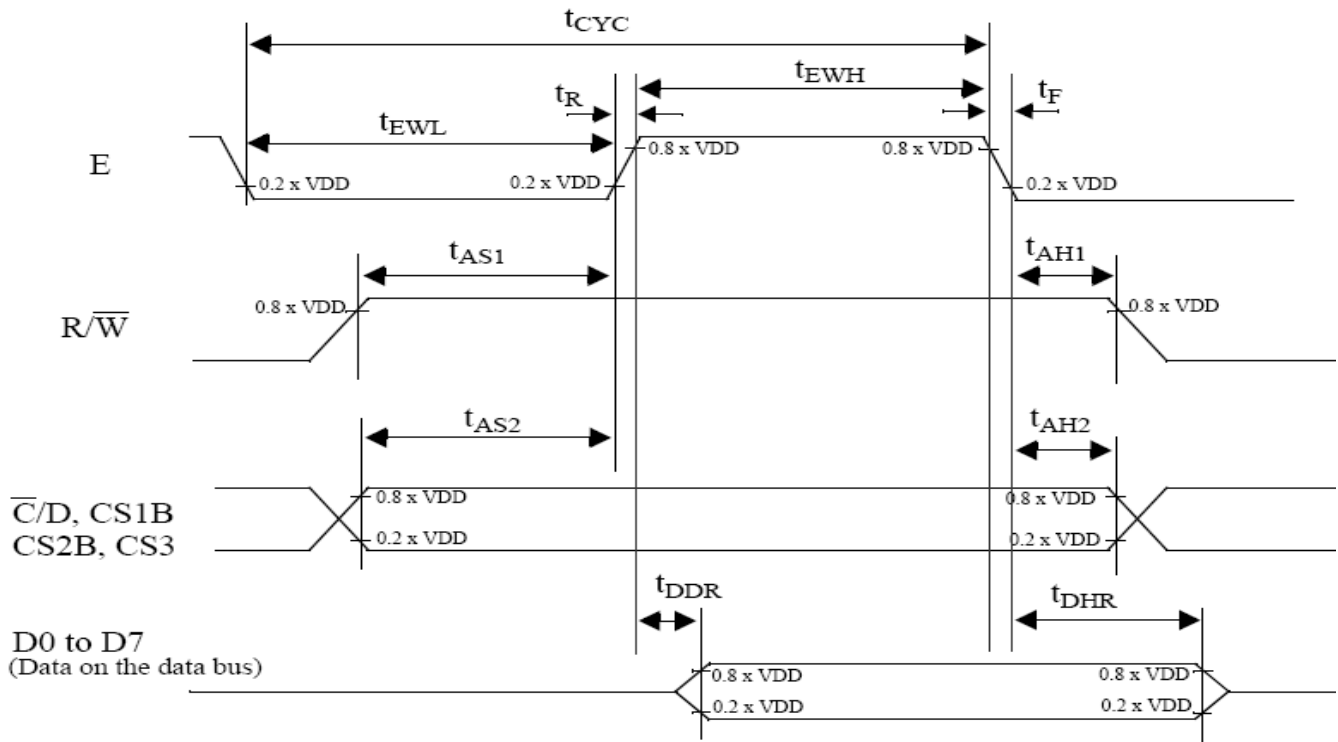

$V_{DD} = 5 V \pm 10\%$; $V_{SS} = 0 V$; $T_{amb} = -20\text{ }^{\circ}\text{C}$ to $+75\text{ }^{\circ}\text{C}$.

symbol	parameter	min.	max.	test conditions	unit
t_{CYC}	Enable (E) cycle time	1000			ns
t_{EWL}	Enable (E) LOW width	450			
t_{EWH}	Enable (E) HIGH width	450			
t_R	Enable (R) rise time		20		
t_F	Enable (F) fall time		20		
t_{AS1}	READ set-up time	140			
t_{AH1}	READ hold time	20			
t_{AS2}	C/D, CS1B, CS2B, CS3 set-up time	140			
t_{AH2}	C/D, CS1B, CS2B, CS3 hold time	10			
t_{DDR}	Data delay time (on the data bus)	320		The loading on the data bus is shown in Fig. 18.	
t_{DHR}	Data hold time (on the data bus)	20			

6. INSTRUCTION SET

Register Name	Description	States after RESET
Display ON/OFF Register	The Display ON/OFF Register is a 1-bit register. After RESET, its value is LOW and, therefore, the LCD display is turned OFF.	0
Display Start Line Register	The Display Start Line Register is a 6-bit register. After RESET, its value is 00 0000 and, therefore, Row 0 of the Display Data Memory is mapped to COM0 of LCD panel.	00 0000
Page Address Register	The Page Address Register is a 3-bit register. It point to a page of the Display Data Memory.	xxx
Column Address Register	The Column Address Register is a 6-bit register.	xx xxxx
Status Register	The Status Register shows the current state of the SBN0064G. It is a 3-bit register, with each bit showing the status of a programmed function.	0010 0000

6.1 Display ON/OFF Register

\overline{C}/D	R/\overline{W}
0	0

D7(MSB)	D6	D5	D4	D3	D2	D1	D0(LSB)
0	0	1	1	1	1	1	D0

6.2 Display Start Line Register

D7(MSB)	D6	D5	D4	D3	D2	D1	D0(LSB)
1	1	A5	A4	A3	A2	A1	A0

A5 ~ A0 are Display Start Line address bits and can be programmed with a value in the range from 0 to 63. Therefore, the code can be from 1100 0000 (C0 Hex) to 1111 1111 (FF Hex).

6.3 Page Address Register

D7(MSB)	D6	D5	D4	D3	D2	D1	D0(LSB)
1	0	1	1	1	A2	A1	A0

A2, A1 and A0 are page address bits and can be programmed with a value in the range from 0 to 7. A2 A1 A0=000 selects Page 0; A2 A1 A0=001 selects Page 1; A2 A1 A0=010 selects Page 2, and A2 A1 A0=011 selects Page 3...etc. Therefore, the code can be from 1011 1000 (B8 Hex) to 1011 1111 (BF Hex).

6.4 Column Address Register

D7(MSB)	D6	D5	D4	D3	D2	D1	D0(LSB)
0	1	A5	A4	A3	A2	A1	A0

A5~A0 are column address bits and can be programmed with a value in the range from 0 to 63. Therefore, the code can be from 0100 0000 (40 Hex) to 0111 1111 (7F Hex).

6.5 Status Read and Status Register

\overline{C}/D	R/\overline{W}
0	1

D7(MSB)	D6	D5	D4	D3	D2	D1	D0(LSB)
BUSY	0	ON/OFF	RESET	0	0	0	0

6.6 The Status Register bit description

Bit	Description
BUSY	BUSY=1 indicates that the SBN0064G is currently busy and can not accept new code or data. The SBN0064G is executing an internal operation. BUSY=0 indicates that the SBN0064G is not busy and is ready to accept new code or data.
ON/OFF	The ON/OFF bit indicates the current of status of display. If ON/OFF=0, the display has been turned ON. If ON/OFF=1, the display has been turned OFF. Note that the polarity of this bit is inverse to that of the Display ON/OFF Register.
RESET	RESET=1 indicates that the SBN0064G is currently in the process of being reset. RESET=0 indicates that the SBN0064G is currently in normal operation.

6.7 READ/WRITE operation

Operation	DATA								Description
	D7	D6	D5	D4	D3	D2	D1	D0	
Write Display Data	Data to be written into the Display Data Memory.								Write a byte of data to the Display Data Memory. The data to be written is put on the data bus by the host microcontroller.
Read Display Data	Data read from the Display Data Memory output latch.								Read a byte of data from the Display Data Memory. The data read from the internal 8-bit output latch (refer to Fig. 12) appears on the data bus. A dummy read is needed to get correct value.

The setting of the control bus for Write Display Data operation

$\overline{C/D}$	R/\overline{W}
1	0

The setting of the control bus for Read Display Data command

$\overline{C/D}$	R/\overline{W}
1	1

7. QUALITY SPECIFICATIONS

7-1. LCM Appearance and Electric inspection Condition

1. Inspection will be done by placing LCM 30cm away from inspector's eyeballs under normal illumination.

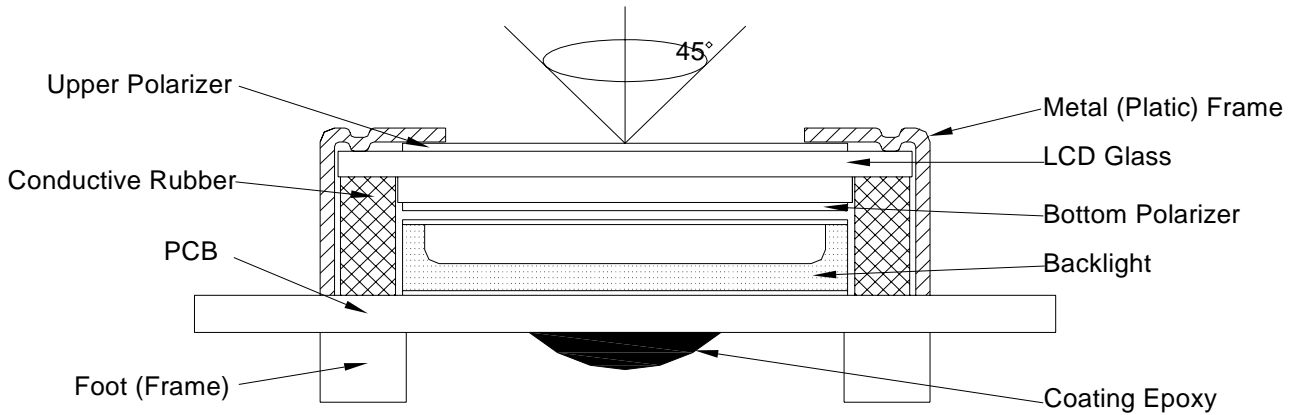

2. View Angle: with in 45° around perpendicular line.

7-2. Definition

1. COB

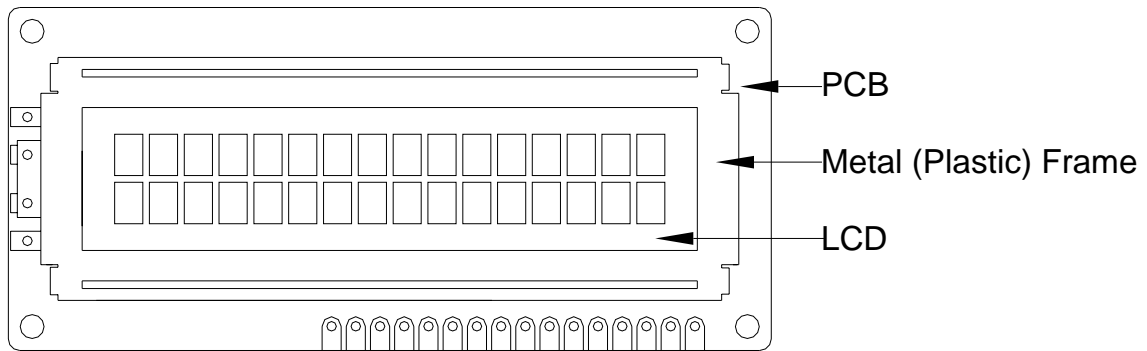

2. Heat Seal

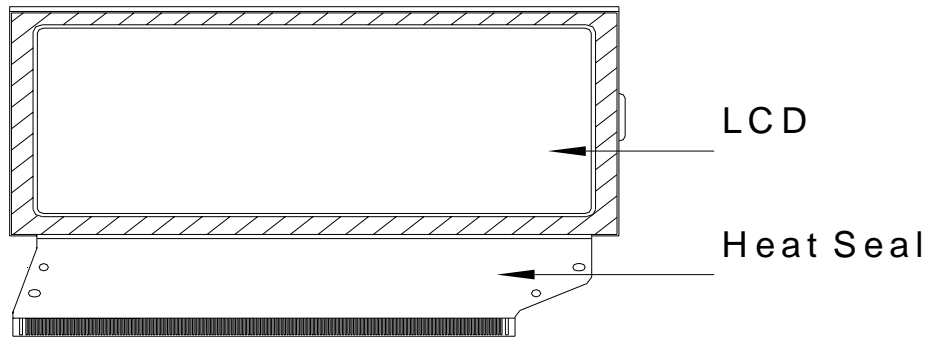

3. TAB and COG

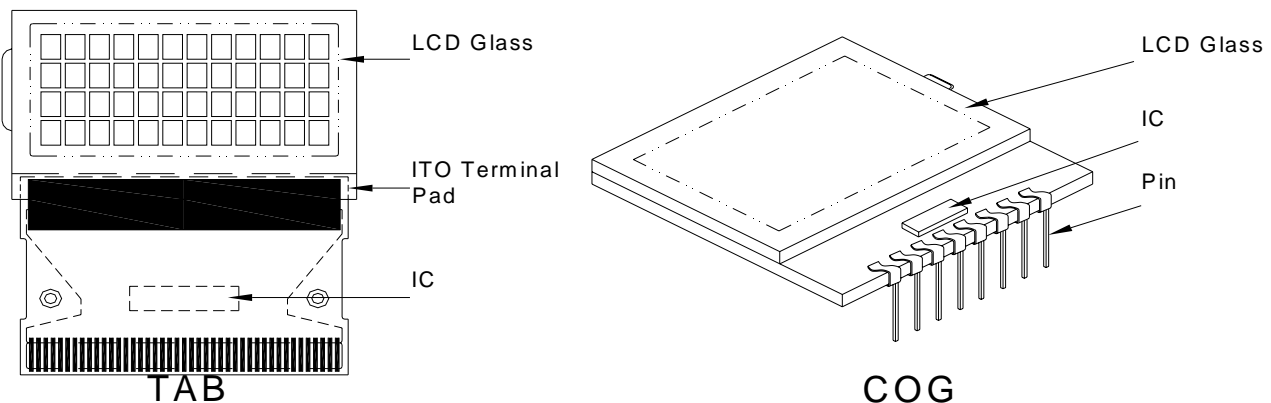

7-3. Sampling Plan and Acceptance

1. Sampling Plan

MIL - STD - 105E (||) ordinary single inspection is used.

2. Acceptance

Major defect: AQL = 0.65%

Minor defect: AQL = 1.5%

7-4. Criteria

1. COB

Defect	Inspection Item	Inspection Standards	
Major	PCB copper flakes peeling off	Any copper flake in viewing Area should be greater than 1.0mm ²	Reject
Major	Height of coating epoxy	Exceed the dimension of drawing	Reject
Major	Void or hole of coating epoxy	Expose bonding wire or IC	Reject
Major	PCB cutting defect	Exceed the dimension of drawing	Reject

2. SMT

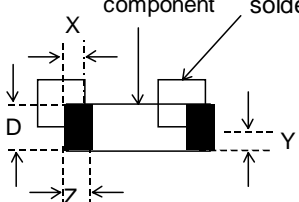
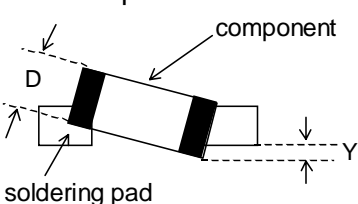
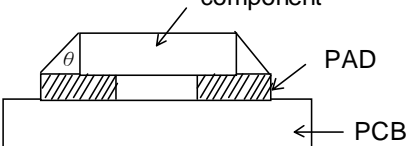
Defect	Inspection Item	Inspection Standards	
Minor	Component marking not readable		Reject
Minor	Component height	Exceed the dimension Of drawing	Reject
Major	Component solder defect (missing , extra, wrong component or wrong orientation)		Reject
Minor	<p>Component position shift</p> 	$X < 3/4Z$ $Y > 1/3D$	Reject
Minor	<p>Component tilt</p> 	$Y > 1/3D$	Reject
Minor	<p>Insufficient solder</p> 	$\theta \leq 20^\circ$	Reject

3. Metal (Plastic) Frame

Defect	Inspection Item	Inspection Standards		
Major	Crack / breakage	Anywhere		
		Reject		
Minor	Frame Scratch	W	L	Acceptable of Scratch
		$w < 0.1\text{mm}$	Any	Ignore
		$0.1 \leq w < 0.2\text{mm}$	$L \leq 5.0\text{mm}$	2
		$0.2 \leq w < 0.3\text{mm}$	$L \leq 3.0\text{mm}$	1
		$w \geq 0.3\text{mm}$	Any	0
Note: 1. Above criteria applicable to scratch lines with distance greater than 5mm. 2. Scratch on the back side of frame (not visible) can be ignored.				
Minor	Frame Dent , Prick $\Phi = \frac{L + W}{2}$			Acceptable of Dents / Pricks
		$\Phi \leq 1.0\text{mm}$		2
		$1.0 < \Phi \leq 1.5\text{mm}$		1
		$1.5\text{mm} < \Phi$		0
Note : 1. Above criteria applicable to any two dents / pricks with distance greater than 5mm 2. Dent / prick on the back side of frame (not visible) can be ignored				
Minor	Frame Deformation	Exceed the dimension of drawing		
Minor	Metal Frame Oxidation	Any rust		

4. Flexible Film Connector (FFC)

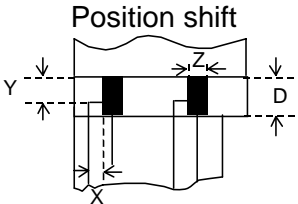
Defect	Inspection Item	Inspection Standards	
Minor	Tilted soldering	Within the angle $+5^\circ$	Acceptable
Minor	Uneven solder joint /bump		Reject
Minor	Hole $\Phi = \frac{L + W}{2}$	Expose the conductive line	Reject
		$\Phi > 1.0\text{mm}$	Reject
Minor	 <p>Position shift</p>	$Y > 1/3D$	Reject
		$X > 1/2Z$	Reject

5. Screw

Defect	Inspection Item	Inspection Standards	
Major	Screw missing/loosen		Reject
Minor	Screw oxidation	Any rust	Reject
Minor	Screw deformation	Difficult to accept screw driver	Reject

6. Heatseal 、TCP 、FPC

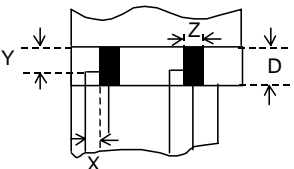
Defect	Inspection Item	Inspection Standards	
Major	Scratch expose conductive layer		Reject
Minor	HS Hole $\Phi = \frac{L+W}{2}$	$\Phi > 0.5\text{mm}$	Reject
Major	Adhesion strength	Less than the specification	Reject
Minor	Position shift 	$Y > 1/3D$	Reject
		$X > 1/2Z$	Reject
Major	Conductive line break		Reject

7. LED Backing Protective Film and Others

Defect	Inspection Item	Inspection Standards	
Minor	LED dirty, prick	Acceptable number of units	
		$\Phi \leq 0.10\text{mm}$	ignore
		$0.10 < \Phi \leq 0.15\text{mm}$	2
		$0.15 < \Phi \leq 0.2\text{mm}$	1
		$\Phi > 0.2\text{mm}$	0
		The distance between any two spots should be $\geq 5\text{mm}$ Any spot/dot/void outside of viewing area is acceptable	
Minor	Protective film tilt	Not fully cover LCD	Reject
Major	COG coating	Not fully cover ITO circuit	Reject

8. Electric Inspection

Defect	Inspection Item	Inspection Standards	
Major	Short		Reject
Major	Open		Reject

9. Inspection Specification of LCD

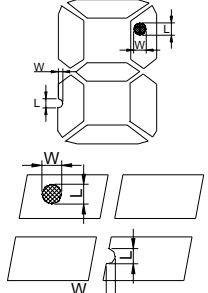
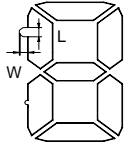
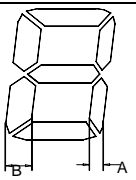
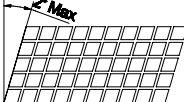
Defect	Inspect Item	Inspection Standards				
		W	$W \leq 0.03$	$0.03 < W \leq 0.05$	$W > 0.05$	
Minor	Linear Defect * Glass Scratch * Polarizer Scratch * Fiber and Linear material	L	$L < 5$	$L < 3$	Any	
		ACC. NO.	1	1	Reject	
		Note	L is the length and W is the width of the defect			
Minor	Black Spot and Polarizer Pricked * Foreign material between glass and polarizer or glass and glass * Polarizer hole or protuberance by external force	Φ	$\Phi \leq 0.1$	$0.1 < \Phi \leq 0.15$	$0.15 < \Phi \leq 0.2$	$\Phi > 0.2$
		ACC. NO.	3EA / 100mm ²	2	1	0
		Note	Φ is the average diameter of the defect. Distance between two defects > 10mm.			
Minor	White Spot and Bubble in polarizer * Unobvious transparent foreign material between glass and glass or glass and polarizer * Air protuberance between polarizer and glass	Φ	$\Phi \leq 0.3$	$0.3 < \Phi \leq 0.5$	$0.5 < \Phi$	
		ACC. NO.	3EA / 100mm ²	1	0	
		Note	Φ is the average diameter of the defect. Distance between two defects > 10mm.			
Minor	Segment Defect 	Φ	$\Phi \leq 0.10$	$0.10 < \Phi \leq 0.20$	$0.20 < \Phi \leq 0.25$	$\Phi > 0.25$
		ACC. NO.	3EA / 100mm ²	2	1	0
		Note	W is more than 1/2 segment width			Reject
			$\Phi = \frac{L + W}{2}$ Distance between two defect is 10mm			
Minor	Protuberant Segment  $\Phi = (L + W) / 2$	Φ	$\Phi \leq 0.10$	$0.10 < \Phi \leq 0.20$	$0.20 < \Phi \leq 0.25$	$\Phi > 0.25$
		W	Glue	$W \leq 1/2$ Seg $W \leq 0.2$	$W \leq 1/2$ Seg $W \leq 0.2$	Ignore
		ACC. NO.	3EA / 100mm ²	2	1	0
Minor	Assembly Mis-alignment  	1. Segment				
		B	$B \leq 0.4\text{mm}$	$0.4 < B \leq 1.0\text{mm}$	$B > 1.0\text{mm}$	
		B-A	$B-A < 1/2B$	$B-A < 0.2$	$B-A < 0.25$	
		Judge	Acceptable	Acceptable	Acceptable	
		2. Dot Matrix				
		Deformation > 2°				Reject
Minor	Stain on LCD Panel Surface	Accept when stains can be wiped lightly with a soft cloth or a similar one. Otherwise, judged according to the above items: "Black spot" and "White Spot"				

8. RELIABILITY

NO.	Item	Condition	Criterion
1	High Temperature Operating	70°C , 96Hrs	No defect in cosmetic and operational function allowable. Total current Consumption should be below double of initial value.
2	Low Temperature Operating	-20°C , 96Hrs	
3	High Humidity	40°C , 90%RH, 96Hrs	
4	High Temperature Storage	80°C , 96Hrs	
5	Low Temperature Storage	-30°C , 96Hrs	
6	Vibration	Random wave 10 ~ 100Hz Acceleration: 2g 2 Hrs per direction(X,Y,Z)	
7	Thermal Shock	-20°C to25°C to70°C (60Min) (5Min) (60Min) 16Cycles	
8	ESD Testing	Contract Discharge Voltage: +1 ~ 4kV and -1 ~ -4kV Air Discharge Voltage: +1 ~ 6kV and -1 ~ -6kV	There will be discharged ten times at every discharging voltage cycle. The voltage gap is 1kV.

Note: 1) Above conditions are suitable for our company standard products.

2) For restrict products, the test conditions listed as above must be revised.

9. HANDLING PRECAUTION

(1) Mounting Method

The panel of the LCD Module consists of two thin glass plates with polarizers, which easily get damaged since the Module is fixed by utilizing fitting holes in the printed circuit board.

Extreme care should be taken when handling the LCD Modules.

(2) Caution of LCD handling & cleaning

When cleaning the display surface, use soft cloth with solvent (recommended below) and wipe lightly.

- Isopropyl alcohol
- Ethyl alcohol
- Tricolor trifler thane

Do not wipe the display surface with dry or hard materials that will damage the polarizer surface.

Do not use the following solvent:

- Water- Kenton- Aromatics

(3) Caution against static charge

The LCD Module use C-MOS LSI drivers, so we recommend that you connect any unused input terminal to VDD or VSS, do not input any signals before power is turned on. And ground your body, Work/assembly table. And assembly equipment to protect against static electricity.

(4) Packaging

- Modules use LCD elements, and must be treated as such. Avoid intense shock and falls from a height.
- To prevent modules from degradation. Do not operate or store them exposed directly to sunshine or high temperature/humidity.

(5) Caution for operation

- It is indispensable to drive LCD's within the specified voltage limit since the higher voltage than the limit shortens LCD life. An electrochemical reaction due to direct current causes LCD deterioration, Avoid the use of direct current drive.
- Response time will be extremely delayed at lower temperature than the operating temperature range and on the other hand at higher temperature LCD's show dark color in them. However those phenomena do not mean malfunction or out of order with LCD's. Which will come back in the specified operating temperature range.
- If the display area is pushed hard during operation, some font will be abnormally displayed but it resumes normal condition after turning off once.
- A slight dew depositing on terminals is a cause for electro-chemical reaction resulting in terminal open circuit.

Usage under the relative condition of 40°C, 50%RH or less is required.

(6) Storage

In the case of storing for a long period of time (for instance.) For years) for the purpose or replacement use, the following ways are recommended.

- Storage in a polyethylene bag with sealed so as not to enter fresh air outside in it, And with no desiccant.
- Placing in a dark place where neither exposure to direct sunlight nor light is. Keeping temperature in the specified storage temperature range.
- Storing with no touch on polarizer surface by the anything else. (It is recommended to store them as they have been contained in the inner container at the time of delivery)

(7) Safety

- It is recommendable to crash damaged or unnecessary LCD into pieces and wash off liquid crystal by using solvents such as acetone and ethanol.

Which should be burned up later.

- When any liquid crystal leaked out of a damaged glass cell comes in contact with your hands, please wash it off well with soap and water.

10. OUTLINE DIMENSION

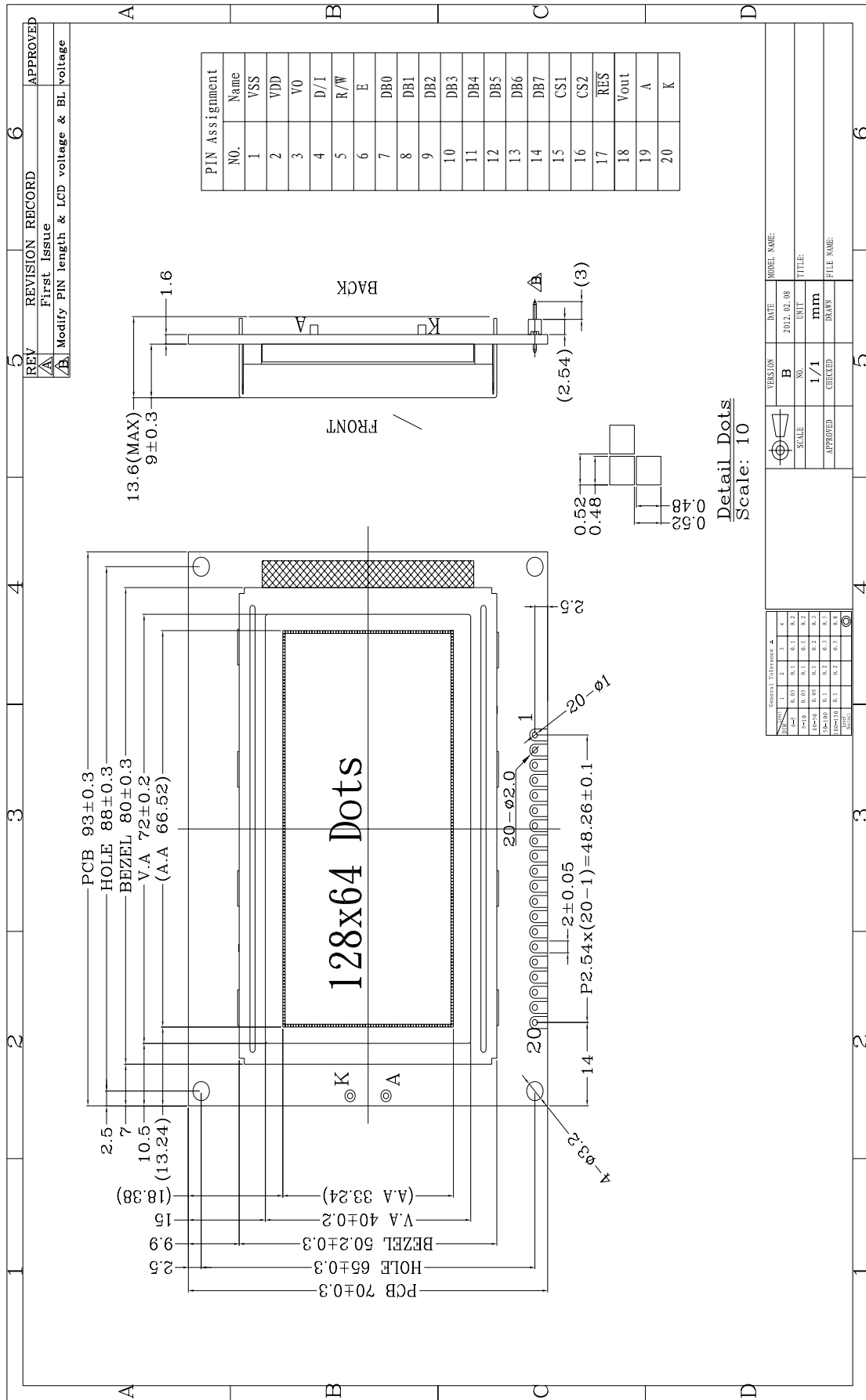

Detail Dots
Scale: 10

REV	REVISION RECORD	APPROVED
5	First Issue	
6	Modify PIN length & LCD voltage & BL voltage	

DATE	DESIGNER	CHECKED	DATE	DATE	MODEL NAME:
2012.02.08					

VERSION	DATE	UNIT
B	2012.02.08	mm

NO.	TITLE:	FILE NAME:
1/1		

General Tolerance	1	2	3	4
±0.10	±0.1	±0.1	±0.2	±0.3
±0.20	±0.15	±0.1	±0.2	±0.3
±0.30	±0.1	±0.2	±0.3	±0.5
±0.40	±0.1	±0.2	±0.3	±0.5