

# LEADER TIME SRL

## PRODUCT SPECIFICATION

**128\*64 Graphic COG LCD MODULE**  
**MODEL: EX0541-803-1 Ver:1.2**

< ◇ > Finally Specification

CUSTOMER'S APPROVAL	
CUSTOMER :	
SIGNATURE:	DATE:

APPROVED BY	PM REVIEWD	PD REVIEWD	PREPARED By

Prepared By:  
LEADER TIME SRL  
VIA MONS. PROSDOCIMI, 27  
36042 BREGANZE (VI)

- This specification is subject to change without notice. Please contact LT or its representative before designing your product based on this specification.



## Table of Contents

No.	Contents	Page
1.	FEATURES.....	4
2.	MECHANICAL SPECIFICATIONS .....	4
3.	ELECTRICAL SPECIFICATIONS .....	4
4.	TERMINAL FUNCTIONS AND BLOCK DIAGRAM.....	6
5.	TIMING CHARACTERISTICS .....	7
6.	COMMAND LIST .....	8
7.	QUALITY SPECIFICATIONS .....	9
8.	RELIABILITY.....	14
9.	HANDLING PRECAUTION.....	15
10.	OUTLINE DIMENSION.....	16

## 1. FEATURES

The features of LCD are as follows

- \* Display mode : STN/BLUE/Transmissive/Negative
- \* Drive IC : ST7567
- \* Interface Input Data : 8bits/6800
- \* Driving Method : 1/65 Duty, 1/9 Bias
- \* Viewing Direction : 12 O'clock
- \* Backlight : 3 LED/Side White
- \* Sample NO. : G1206U7SGW2G-B0\_03/20180806

## 2. MECHANICAL SPECIFICATIONS

Item	Specification	Unit
Module Size	67.15(W) x 45.54(H) x 5.5MAX(D)	mm
Number of Dots	128 x 64 Dots	-
Viewing Area	61 (W) x 31.4(H)	mm
Activity Area	54.99(W) x 27.47(H)	mm
Dot Size	0.38(W) x 0.38(H)	mm
Dot Pitch	0.43(W) x 0.43(H)	mm

## 3. ELECTRICAL SPECIFICATIONS

### 3-1 ABSOLUTR MAXIMUM RATINGS (Ta = 25 °C)

Item	Symbol	Standard Value		Unit
		Min.	Max.	
Supply Voltage For Logic	$V_{DD} - V_{SS}$	-0.3	3.6	V
Supply Voltage For LCD Drive	$V_{O-} - V_{SS}$	-0.3	16	V
Input Voltage	$V_{in}$	-0.3	$V_{DD}+0.3$	V
Operating Temp.	Top	0	+50	°C
Storage Temp.	Tst	-10	+60	°C

### 3-2 ELECTRICAL CHARACTERISTICS

Item	Symbol	Test Condition	Min.	Typ.	Max.	Unit	
Logic supply Voltage	$V_{DD} - V_{SS}$	$T_a = 25\text{ }^\circ\text{C}$ $V_{DD}=3.0V \pm 5\%$	2.7	3.0	3.3	V	
LCD Drive	$V_0 - XV_0$		8.2	8.5	8.8	V	
Input Voltage	"H" Level		$V_{IH}$	$0.7V_{DD}$	-	$V_{DD}$	V
	"L" Level		$V_{IL}$	$V_{SS}$	-	$0.3V_{DD}$	V
Frame Frequency	$f_{FLM}$		-	75	-	Hz	
Current Consumption	$I_{DD}$		-	0.15	-	mA	

\*NOTE:The response time will be extremely slow when the operating temperature is around  $-20\text{ }^\circ\text{C}$ , and the back ground will become darker at high temperature operating.

### 3-3. BACKLIGHT

#### 3-3-1. Absolute Maximum Ratings

Item	Symbol	Condition	Min.	Typ.	Max.	Unit
Forward Current	$I_{fm}$	$T_a = 25\text{ }^\circ\text{C}$	-	-	$25*3$	mA
Reverse Voltage	$V_r$		-	-	5	V
Power Dissipation	$P_d$		-	-	240	mW

#### 3-3-2. Electrical-optical Characteristics

Item	Symbol	Condition	Min.	Typ.	Max.	Unit
Forward Current	$I_f$	$V_f = 3.2V$ $T_a = 25\text{ }^\circ\text{C}$	-	45	54	mA
Luminance	$L_v$		300	-	-	$\text{cd/m}^2$
Colour Coordinate	X		0.25	0.28	0.31	-
	Y		0.25	0.28	0.31	

\*NOTE:The brightness is measured without LCD panel.

For operation above  $25\text{ }^\circ\text{C}$ ,The  $I_{fm}$ & $P_d$  must be derated,the current derating is  $-0.36\text{mA}/^\circ\text{C}$  for DC drive and  $-0.86\text{mA}/^\circ\text{C}$  for Pulse drive ,the Power dissipation is  $-0.75\text{mW}/^\circ\text{C}$ .The product working current must not more than the 60%of the  $I_{fm}$  or  $I_{fp}$  according to the working temperature.



## 5. TIMING CHARACTERISTICS

### System Bus Timing for 6800 Series MPU

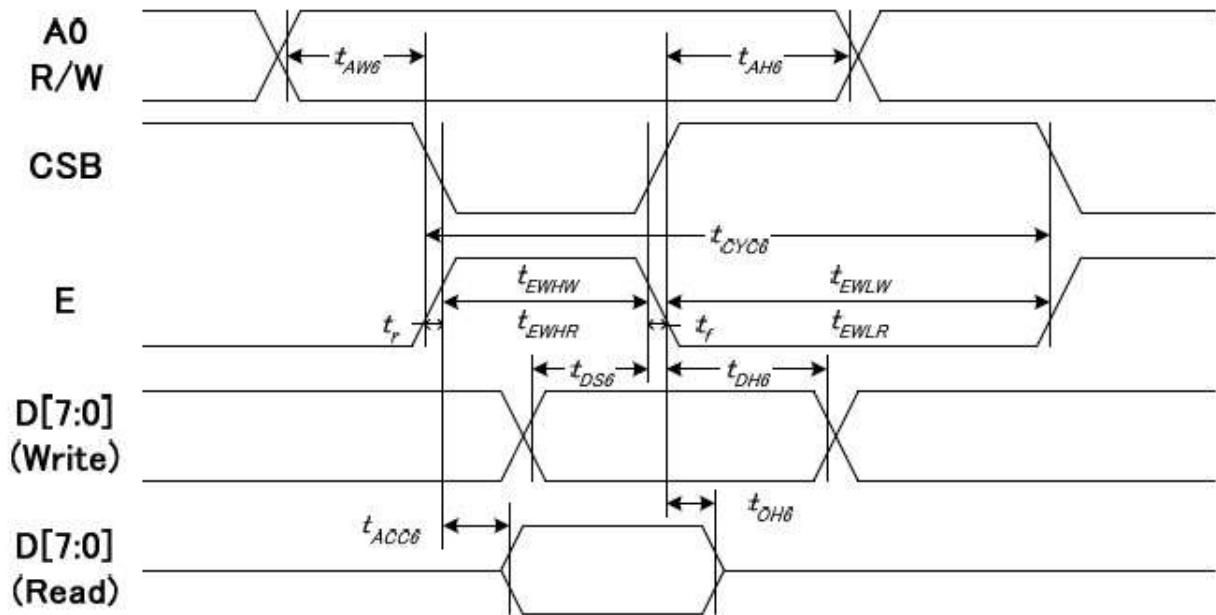

(VDD1 = 3.3V, Ta = 25°C)

Item	Signal	Symbol	Condition	Min.	Max.	Unit
Address setup time	A0	tAW6		0	—	ns
Address hold time		tAH6		10	—	
System cycle time	E	tCYC6		240	—	
Enable L pulse width (WRITE)		tEHLW		80	—	
Enable H pulse width (WRITE)		tEHWLW		80	—	
Enable L pulse width (READ)		tEHLR		80	—	
Enable H pulse width (READ)	tEHWHR		140	—		
Write data setup time	D[7:0]	tDS6		40	—	
Write data hold time		tDH6		10	—	
Read data access time		tACC6	CL = 16 pF	—	70	
Read data output disable time		tOH6	CL = 16 pF	5	50	

\*1 The input signal rise time and fall time (tr, tf) is specified at 15 ns or less. When the system cycle time is extremely fast, (tr + tf) ≤ (tCYC6 - tEHLW - tEHWLW) for (tr + tf) ≤ (tCYC6 - tEHLR - tEHWHR) are specified.

\*2 All timing is specified using 20% and 80% of VDD1 as the reference.

\*3 tEHLW and tEHLR are specified as the overlap between CSB being "L" and E.

## 6. INSTRUCTION SET

INSTRUCTION	A0	R/W (RWR)	COMMAND BYTE								DESCRIPTION
			D7	D6	D5	D4	D3	D2	D1	D0	
(1) Display ON/OFF	0	0	1	0	1	0	1	1	1	D	D=1, display ON D=0, display OFF
(2) Set Start Line	0	0	0	1	S5	S4	S3	S2	S1	S0	Set display start line
(3) Set Page Address	0	0	1	0	1	1	Y3	Y2	Y1	Y0	Set page address
(4) Set Column Address	0	0	0	0	0	1	X7	X6	X5	X4	Set column address (MSB)
	0	0	0	0	0	0	X3	X2	X1	X0	Set column address (LSB)
(5) Read Status	0	1	0	MX	D	RST	0	0	0	0	Read IC Status
(6) Write Data	1	0	D7	D6	D5	D4	D3	D2	D1	D0	Write display data to RAM
(7) Read Data	1	1	D7	D6	D5	D4	D3	D2	D1	D0	Read display data from RAM
(8) SEG Direction	0	0	1	0	1	0	0	0	0	MX	Set scan direction of SEG MX=1, reverse direction MX=0, normal direction
(9) Inverse Display	0	0	1	0	1	0	0	1	1	INV	INV =1, inverse display INV =0, normal display
(10) All Pixel ON	0	0	1	0	1	0	0	1	0	AP	AP=1, set all pixel ON AP=0, normal display
(11) Bias Select	0	0	1	0	1	0	0	0	1	BS	Select bias setting 0=1/9; 1=1/7 (at 1/65 duty)
(12) Read-modify-Write	0	0	1	1	1	0	0	0	0	0	Column address increment: Read:+0 , Write:+1
(13) END	0	0	1	1	1	0	1	1	1	0	Exit Read-modify-Write mode
(14) RESET	0	0	1	1	1	0	0	0	1	0	Software reset
(15) COM Direction	0	0	1	1	0	0	MY	-	-	-	Set output direction of COM MY=1, reverse direction MY=0, normal direction
(16) Power Control	0	0	0	0	1	0	1	VB	VR	VF	Control built-in power circuit ON/OFF
(17) Regulation Ratio	0	0	0	0	1	0	0	RR2	RR1	RR0	Select regulation resistor ratio
(18) Set EV	0	0	1	0	0	0	0	0	0	1	Double command!! Set electronic volume (EV) level
	0	0	0	0	EV5	EV4	EV3	EV2	EV1	EV0	
(19) Set Booster	0	0	1	1	1	1	1	0	0	0	Double command!! Set booster level: BL=0: 4X BL=1: 5X
	0	0	0	0	0	0	0	0	0	BL	
(20) Power Save	0	0	Compound Command								Display OFF + All Pixel ON
(21) NOP	0	0	1	1	1	0	0	0	1	1	No operation
(22) Test	0	0	1	1	1	1	1	1	1	-	Do NOT use. Reserved for testing.

Note: Symbol "-" means this bit can be "H" or "L".



## 7. QUALITY SPECIFICATIONS

### 7 - 1. LCM Appearance and Electric inspection Condition

1. Inspection will be done by placing LCM 30cm away from inspector's eyeballs under normal illumination.

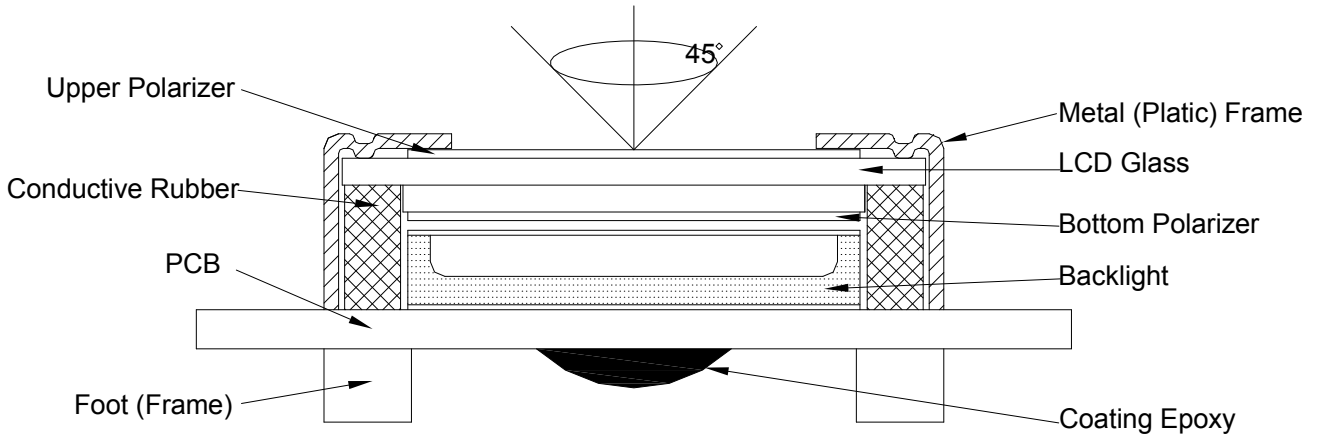

2. View Angle: with in 45° around perpendicular line.

### 7 - 2. Definition

#### 1. COB

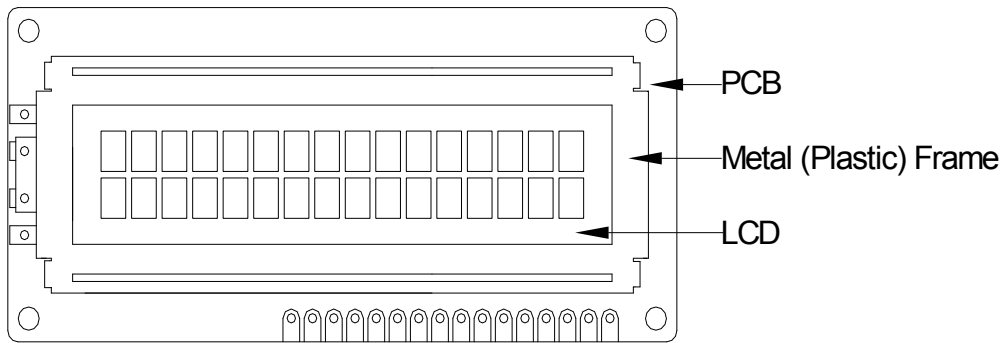

#### 2. Heat Seal

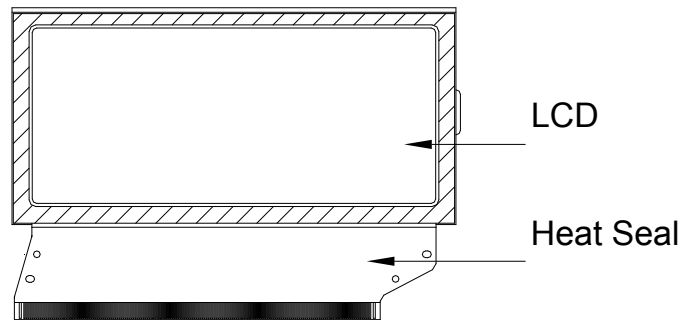

#### 3. TAB and COG

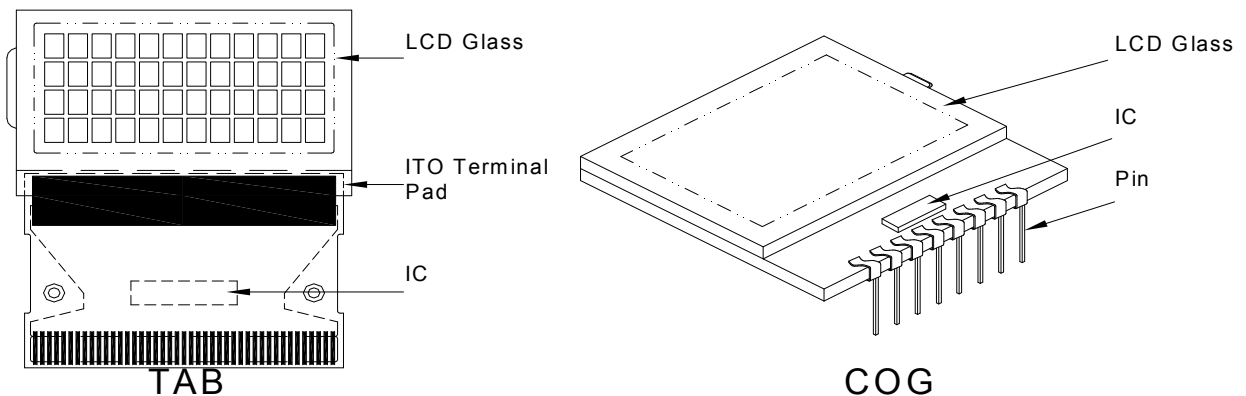

### 7-3. Sampling Plan and Acceptance

#### 1. Sampling Plan

MIL - STD - 105E (II) ordinary single inspection is used.

#### 2. Acceptance

Major defect: AQL = 0.65%

Minor defect: AQL = 1.5%

### 7-4. Criteria

#### 1. COB

Defect	Inspection Item	Inspection Standards	
Major	PCB copper flakes peeling off	Any copper flake in viewing Area should be greater than 1.0mm <sup>2</sup>	Reject
Major	Height of coating epoxy	Exceed the dimension of drawing	Reject
Major	Void or hole of coating epoxy	Expose bonding wire or IC	Reject
Major	PCB cutting defect	Exceed the dimension of drawing	Reject

#### 2. SMT

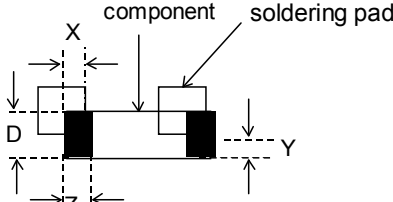
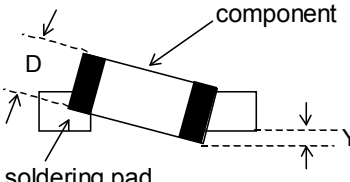
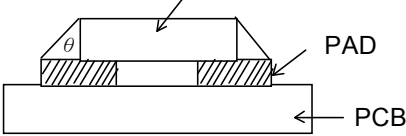
Defect	Inspection Item	Inspection Standards	
Minor	Component marking not readable		Reject
Minor	Component height	Exceed the dimension Of drawing	Reject
Major	Component solder defect (missing , extra, wrong component or wrong orientation)		Reject
Minor	Component position shift 	$X < 3/4Z$ $Y > 1/3D$	Reject Reject
Minor	Component tilt 	$Y > 1/3D$	Reject
Minor	Insufficient solder 	$\theta \leq 20^\circ$	Reject

### 3. Metal (Plastic) Frame

Defect	Inspection Item	Inspection Standards		
Major	Crack / breakage	Anywhere		
			Reject	
Minor	Frame Scratch	W	L	Acceptable of Scratch
		w<0.1mm	Any	Ignore
		0.1≤w<0.2mm	L≤5.0mm	2
		0.2≤w<0.3mm	L≤3.0mm	1
		w>0.3mm	Any	0
		Note : 1. Above criteria applicable to scratch lines with distance greater than 5mm. 2. Scratch on the back side of frame (not visible) can be ignored .		
Minor	Frame Dent , Prick $\Phi = \frac{L + W}{2}$			Acceptable of Dents / Pricks
		$\Phi \leq 1.0\text{mm}$		2
		$1.0 < \Phi \leq 1.5\text{mm}$		1
		$1.5\text{mm} < \Phi$		0
Note : 1. Above criteria applicable to any two dents / pricks with distance greater than 5mm 2. Dent / prick on the back side of frame (not visible) can be ignored				
Minor	Frame Deformation	Exceed the dimension of drawing		
Minor	Metal Frame Oxidation	Any rust		

### 4. Flexible Film Connector (FFC)

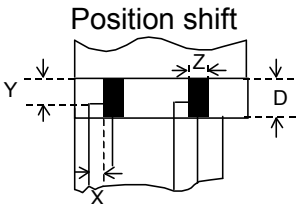
Defect	Inspection Item	Inspection Standards	
Minor	Tilted soldering	Within the angle +5°	Acceptable
Minor	Uneven solder joint /bump		Reject
Minor	Hole $\Phi = \frac{L + W}{2}$	Expose the conductive line	Reject
		$\Phi > 1.0\text{mm}$	Reject
Minor	 <p>Position shift</p>	$Y > 1/3D$	Reject
		$X > 1/2Z$	Reject

### 5. Screw

Defect	Inspection Item	Inspection Standards	
Major	Screw missing/loosen		Reject
Minor	Screw oxidation	Any rust	Reject
Minor	Screw deformation	Difficult to accept screw driver	Reject

### 6. Heatseal 、TCP 、FPC

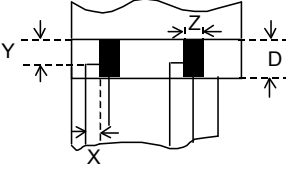
Defect	Inspection Item	Inspection Standards	
Major	Scratch expose conductive layer		Reject
Minor	HS Hole $\Phi = \frac{L+W}{2}$	$\Phi > 0.5\text{mm}$	Reject
Major	Adhesion strength	Less than the specification	Reject
Minor	Position shift 	$Y > 1/3D$	Reject
		$X > 1/2Z$	Reject
Major	Conductive line break		Reject

### 7. LED Backing Protective Film and Others

Defect	Inspection Item	Inspection Standards	
Minor	LED dirty, prick	Acceptable number of units	
		$\Phi \leq 0.10\text{mm}$	Ignore
		$0.10 < \Phi \leq 0.15\text{mm}$	2
		$0.15 < \Phi \leq 0.2\text{mm}$	1
		$\Phi > 0.2\text{mm}$	0
		The distance between any two spots should be $\geq 5\text{mm}$ Any spot/dot/void outside of viewing area is acceptable	
Minor	Protective film tilt	Not fully cover LCD	Reject
Major	COG coating	Not fully cover ITO circuit	Reject

### 8. Electric Inspection

Defect	Inspection Item	Inspection Standards	
Major	Short		Reject
Major	Open		Reject

### 9. Inspection Specification of LCD

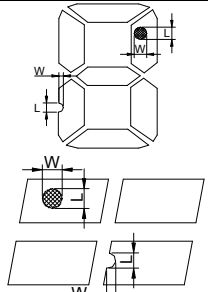
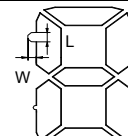
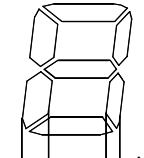
Defect	Inspect Item		Inspection Standards				
Minor	Linear Defect	* Glass Scratch * Polarizer Scratch * Fiber and Linear material	W	$W \leq 0.03$	$0.03 < W \leq 0.05$	$W > 0.05$	
			L	$L < 5$	$L < 3$	Any	
			ACC. NO.	1	1	Reject	
			Note	L is the length and W is the width of the defect			
Minor	Black Spot and Polarizer Pricked	* Foreign material between glass and polarizer or glass and glass * Polarizer hole or protuberance by external force	$\Phi$	$\Phi \leq 0.1$	$0.1 < \Phi \leq 0.15$	$0.15 < \Phi \leq 0.2$	$\Phi > 0.2$
			ACC. NO.	3EA / 100mm <sup>2</sup>	2	1	0
			Note	$\Phi$ is the average diameter of the defect. Distance between two defects > 10mm.			
Minor	White Spot and Bubble in polarizer	* Unobvious transparent foreign material between glass and glass or glass and polarizer * Air protuberance between polarizer and glass	$\Phi$	$\Phi \leq 0.3$	$0.3 < \Phi \leq 0.5$	$0.5 < \Phi$	
			ACC. NO.	3EA / 100mm <sup>2</sup>	1	0	
			Note	$\Phi$ is the average diameter of the defect. Distance between two defects > 10mm.			
Minor	Segment Defect		$\Phi$	$\Phi \leq 0.10$	$0.10 < \Phi \leq 0.20$	$0.20 < \Phi \leq 0.25$	$\Phi > 0.25$
			ACC. NO.	3EA / 100mm <sup>2</sup>	2	1	0
			Note	W is more than 1/2 segment width			Reject
				$\Phi = \frac{L + W}{2}$ Distance between two defect is 10mm			
Minor	Protuberant Segment	 $\Phi = (L + W) / 2$	$\Phi$	$\Phi \leq 0.10$	$0.10 < \Phi \leq 0.20$	$0.20 < \Phi \leq 0.25$	$\Phi > 0.25$
			W	Glue	$W \leq 1/2$ Seg $W < 0.2$	$W \leq 1/2$ Seg $W < 0.2$	Ignore
			ACC. NO.	3EA / 100mm <sup>2</sup>	2	1	0
Minor	Assembly Mis-alignment		1. Segment				
			B	$B \leq 0.4\text{mm}$	$0.4 < B \leq 1.0\text{mm}$	$B > 1.0\text{mm}$	
			B-A	$B-A < 1/2B$	$B-A < 0.2$	$B-A < 0.25$	
			Judge	Acceptable	Acceptable	Acceptable	
			2. Dot Matrix				
				Deformation > 2°			Reject
Minor	Stain on LCD Panel Surface		Accept when stains can be wiped lightly with a soft cloth or a similar one. Otherwise, judged according to the above items: "Black spot" and "White Spot"				

## 8. RELIABILITY

No	Item	Condition	Quantity	Criteria
1	High Temperature Operating	50°C, 96Hrs	2	GB/T2423.2-2008
2	Low Temperature Operating	0°C, 96Hrs	2	GB/T2423.1-2008
3	High Humidity	40°C, 90%RH, 96Hrs	2	GB/T2423.3-2006
4	High Temperature Storage	60°C, 96Hrs	2	GB/T2423.2-2008
5	Low Temperature Storage	-10°C, 96Hrs	2	GB/T2423.1-2008
6	Thermal Cycling Test	0°C, 60min~50°C, 60min, 20 cycles.	2	GB/T2423.22-2012
7	Packing vibration	Frequency range:10Hz~50Hz Acceleration of gravity:5G X,Y,Z 30 min for each direction.	2	GB/T5170.14-2009
8	Electrical Static Discharge	Air: ±8KV 150pF/330 Ω 5 times Contact: ±4KV 150pF/330 Ω 5 times	2	GB/T17626.2-2006
9	Drop Test(Packaged)	Height:80 cm,1 corner, 3 edges, 6 surfaces.	2	GB/T2423.8-1995

Note: 1) Above conditions are suitable for our company standard products.  
 2) For restrict products, the test conditions listed as above must be revised.

## 9. HANDLING PRECAUTION

### (1) Mounting Method

The panel of the LCD Module consists of two thin glass plates with polarizers which easily get damaged since the Module is fixed by utilizing fitting holes in the printed circuit board.

Extreme care should be taken when handling the LCD Modules.

### (2) Caution of LCD handling & cleaning

When cleaning the display surface, use soft cloth with solvent (recommended below) and wipe lightly.

- Isopropyl alcohol
- Ethyl alcohol
- Trichloro trifloro thane

Do not wipe the display surface with dry or hard materials that will damage the polarizer surface.

Do not use the following solvent:

- Water
- Ketone
- Aromatics

### (3) Caution against static charge

The LCD Module use C-MOS LSI drivers, so we recommend that you connect any unused input terminal to VDD or VSS, do not input any signals before power is turned on. And ground your body, Work/assembly table. And assembly equipment to protect against static electricity.

### (4) Packaging

- Modules use LCD elements, and must be treated as such. Avoid intense shock and falls from a height.
- To prevent modules from degradation. Do not operate or store them exposed directly to sunshine or high temperature/humidity.

### (5) Caution for operation

- It is indispensable to drive LCD's within the specified voltage limit since the higher voltage than the limit shorten LCD life. An electrochemical reaction due to direct current causes LCD deterioration, Avoid the use of direct current drive.
- Response time will be extremely delayed at lower temperature than the operating temperature range and on the other hand at higher temperature LCD's show dark color in them. However those phenomena do not mean malfunction or out of order with LCD's. Which will come back in the specified operating temperature range.
- If the display area is pushed hard during operation, some font will be abnormally displayed but it resumes normal condition after turning off once.
- A slight dew depositing on terminals is a cause for electro-chemical reaction resulting in terminal open circuit.

Usage under the relative condition of 40°C, 50%RH or less is reequred.

### (6) Storage

In the case of storing for a long period of time (for instance.) For years) for the purpose or replacement use, The following ways are recommended.

- Storage in a polyethylene bag with sealed so as not to enter fresh air outside in it, And with no desiccant.
- Placing in a dark place where neither exposure to direct sunlight nor light is. Keeping temperature in the specified storage temperature range.
- Storing with no touch on polarizer surface by the anything else. (It is recommended to store them as they have been contained in the inner container at the time of delivery)

### (7) Safety

- It is recommendable to crash damaged or unnecessary LCD into pieces and wash off liquid crystal by using solvents such as acetone and ethanol. Which should be burned up later.
- When any liquid crystal leaked out of a damaged glass cell comes in contact with your hands, please wash it off well with soap and water.

# 10. OUTLINE DIMENSION

\*NOTE: The dimension with mark"()" are reference.

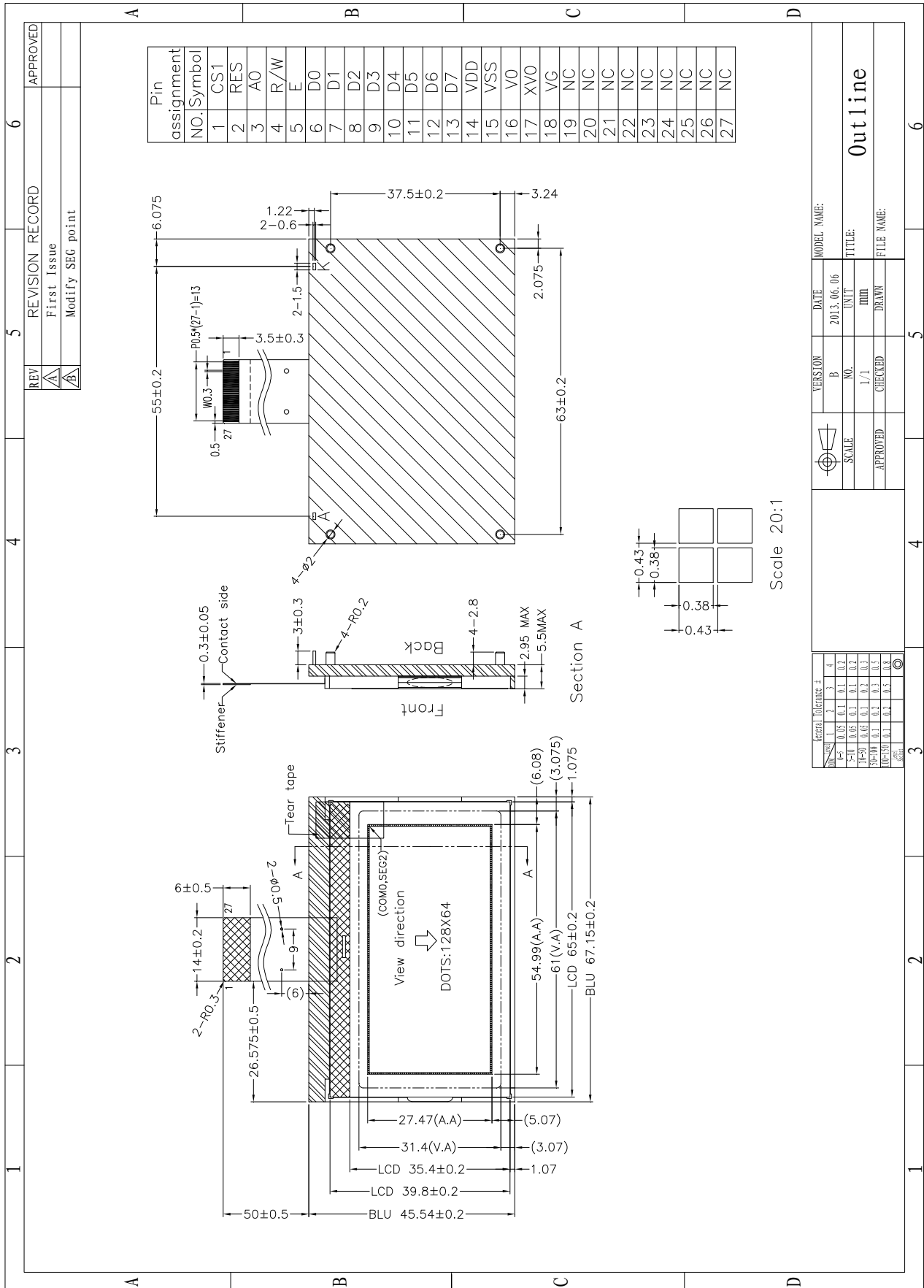

REVISION RECORD		APPROVED
REV	First Issue	
A	Modify SEG point	

VERSION	DATE	MODEL NAME:
B	2013.06.06	
NO.	UNIT	TITLE:
1/1	MM	Outline
CHECKED	DRAWN	FILE NAME:

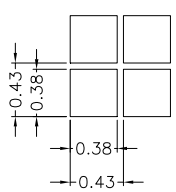

Scale 20:1